

	A	B	C	D	E	F	G	SERIES 2 L DRILL	
INCH	.327	2.234	.900	.350	3.00	2.302	6.188	MAXIMUM RECOMMENDED DRILL DIAMETER	.250 INCH
MM	8.30	56.74	22.86	8.89	76.20	58.47	157.1		6.35 mm

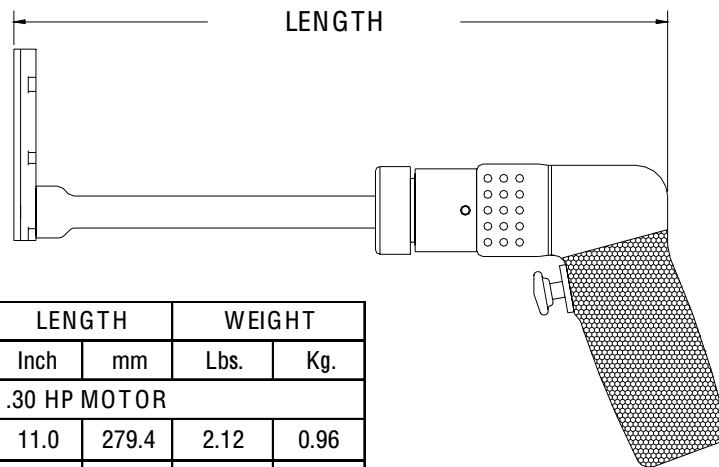

**13817 ATTACHMENT ONLY EXTENDED**

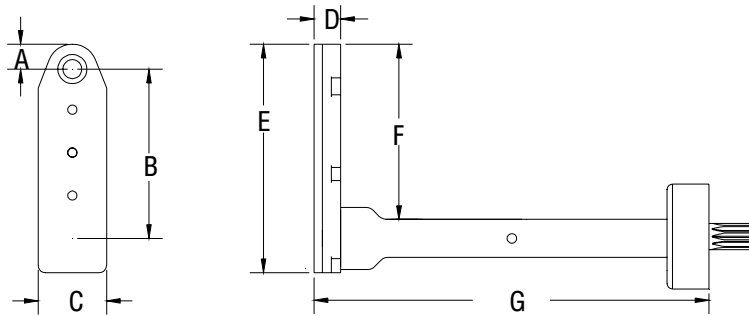

TOOL ORDER NUMBER	R.P.M.	LENGTH		WEIGHT	
		Inch	mm	Lbs.	Kg.
D SERIES .30 HP MOTOR					
16344	250	11.0	279.4	2.12	0.96
14061	500	11.0	279.4	2.12	0.96
14062	750	11.0	279.4	2.12	0.96
14063	1000	11.0	279.4	2.12	0.96
14064	1500	11.0	279.4	2.12	0.96
14065	2800	10.1	256.5	1.84	0.83
D2 SERIES .60 HP MOTOR					
16345	250	12.95	328.9	3.69	1.67
14066	450	12.35	313.6	2.99	1.35
14067	1000	12.35	313.6	2.99	1.35
14068	2000	11.10	281.9	2.74	1.24
14069	2700	11.10	281.9	2.74	1.24
14070	3500	11.10	281.9	2.74	1.24
RD2 .40 HP REVERSIBLE MOTOR					
16346	250	12.95	328.9	3.69	1.67
14071	450	12.35	313.6	3.24	1.46
14072	1000	12.35	313.6	3.24	1.46
14073	2000	11.10	281.9	2.99	1.35
14074	2700	11.10	281.9	2.99	1.35
14075	3500	11.10	281.9	2.99	1.35

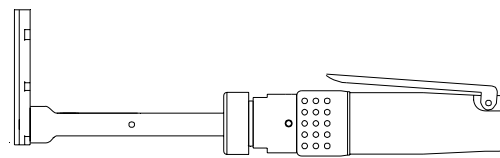

Add an S after the tool order number for the straight handle option.

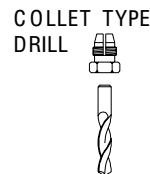

INTERNAL THREAD	
ADD TO TOOL No.	
1/4-28	A
10-32	C
9/32-40	E
5/16-24	F
COLLET	D

PHONE: 1 775 883 1072 FAX: 1 775 883 4857