

## The best equipment deserves the best service

At Ingersoll Rand, we know how important your equipment is to your livelihood. That's why for the past 100 years we've been setting the standard for not just powerful and durable products, but also for providing total solutions that help you get the job done right.

As tough as our equipment is, we also know that it needs to be maintained. When the time comes, let Ingersoll Rand meet your service and repair needs through our expansive Certified Service Network.

Each Certified Service provider has the specialized testing equipment, genuine parts, and skilled training to ensure you're back up and running at original equipment manufacturer (OEM) specifications.

### Global reach, local service

No matter where your facility is located, Ingersoll Rand is committed to serving you 24 hours a day, seven days a week. Our worldwide network of distributors, certified, factory-trained technicians, and engineers are a phone call away — ready to support you with innovative and cost-effective solutions that will keep you running at peak performance.



**Repairs done right.  
Service made simple.**

[irtools.com/tools/fastening](http://irtools.com/tools/fastening)

Distributed by:



Ingersoll Rand Industrial Technologies provides products, services and solutions that enhance our customers' energy efficiency, productivity and operations. Our diverse and innovative products range from complete compressed air systems, tools and pumps to material and fluid handling systems and environmentally friendly microturbines. We also enhance productivity through solutions created by Club Car®, the global leader in golf and utility vehicles for businesses and individuals.

(800) 376-8665 • [irtools.com](http://irtools.com)

© 2009 Ingersoll-Rand Company AS-0206-061

## DC Electric Fastening Systems Tools, Controllers, and Software



# Because every assembly is critical



You've got a critical job to do, and there are a lot of people counting on you to get it done right. At Ingersoll Rand, we know what's at stake, too. That's why we deliver the most innovative and reliable fastening systems in the industry.

Fastening applications involve more than simply selecting tools from a catalog. It's an intricate matter of linking users, applications, and systems to deliver an uncompromised combination of accuracy, durability, speed and ergonomics to maximize your line's productivity. The solution: Ingersoll Rand DC Electric Fastening Systems.

We understand that the ever increasing demand for higher quality, safer, and more environmentally friendly products at a competitive price means our customers need their processes to be best-in-class and cost effective. That is why our dedicated team of professionals design, test, manufacture, and support every component, assembly, and detail of our systems and services to deliver best-in-class, cost-effective solutions for our customers. We do this because we know that we all have a lot riding on our efforts. Work with our team and learn how Ingersoll Rand delivers the complete solution to meet your requirements, including the after-sales service and support you should expect from a leader in the industry.

## Trusted tools, proven experience

Ingersoll Rand has extensive experience with threaded fastening processes. For more than 100 years, we've worked with many of the world's leading manufacturers in various industries. We understand the interface between the tool and operator; we know how to leverage the power of ergonomically designed equipment to maximize productivity and inspire progress.

## Ingersoll Rand fastening portfolio

Ingersoll Rand offers a full line of production fastening equipment, including air and electric screwdrivers, nutrunners, drills, riveters, pulse tools, as well as handheld and multispindle fixtured DC nutrunners. Whether you need a solution for a single, specific application or an entire assembly line, you can trust our century of tool design experience to meet your needs.



### DC ELECTRIC FASTENING SYSTEMS

Handheld Tools	Fixtured Tools	Controllers and Software	Fixtured Systems
<p><b>Tools</b></p> <ul style="list-style-type: none"> <li>• True closed-loop transducerized control delivers exceptional accuracy and traceability</li> <li>• Non-contacting switches, heavy-duty gear trains, superior cables and DC brushless motors provide exceptional reliability</li> <li>• Inline, angle, pistol, offset, and motor configurations allow the flexibility to choose the exact tool required</li> <li>• Bright LEDs provide visible status indicators while TactAlert provides tactile feedback on handheld tools without distracting the operator from the task</li> <li>• World-class ergonomic designs improve operator comfort</li> <li>• Compact, high-speed, easily accessible controls</li> <li>• Torque ranges: 0.3 – 2500 Nm</li> </ul> <p><i>Offering a full line of handheld and fixtured tools — we take accuracy, ergonomics, and reliability to new levels. With inline, angle, pistol, and offset configurations, our tools are engineered to maximize your productivity.</i></p>	<p><b>Controls</b></p> <ul style="list-style-type: none"> <li>• Quick setup and advanced tightening strategies</li> <li>• Complete line of standard and custom communication protocols</li> <li>• SQL server database archiving, searching and statistics processing</li> <li>• Compact, space-saving designs</li> <li>• Crisp, high-visibility full-color 1/4 VGA or one line displays</li> <li>• Standard Ethernet and I/O connections optimize communications and line integration</li> <li>• Remote monitoring and preventive maintenance alerts</li> <li>• Multiple languages</li> </ul> <p><i>Delivering a powerful combination — the ICD&amp;M controllers and ICS Software offer industry leading functionality in a compact size. Advanced tightening strategies and data communications improve process and product quality.</i></p>	<p><b>Quick and Custom Multiples</b></p> <ul style="list-style-type: none"> <li>• Pre-engineered modular or custom engineered designs</li> <li>• Quick multis — for common applications using off-the-shelf components that are quickly configured to meet the job requirements</li> <li>• Custom multis — for more complex applications requiring custom engineering</li> <li>• Use world-class QE, QM, and QA Series tools</li> <li>• Configurable handle and operator interface modules</li> <li>• Quick quoting and delivery</li> <li>• Full engineering and project management capabilities</li> </ul> <p><i>Providing more than just the building blocks for your fastening applications — we offer the global depth of engineering expertise to design and build turnkey, multispindle solutions for nearly any industrial application.</i></p>	

# Tools

## QE and QM Series

Delivering a full line of world-class tools — whether handheld or fixtured, Ingersoll Rand provides superior accuracy, ergonomics, and durability to meet your critical fastening requirements. Whether you are in the motor vehicle, aerospace, electronics, white goods, or general industries, we can help maximize your productivity.

### Features

- Torque coverage from 0.3 to 2500 Nm
- Full closed-loop transducerized control delivers excellent capability
- Highly configurable platforms allow selection of the perfect tool for the application including inline, pistol, angle, offset, and motor configurations
- All models are compatible with both ICD and ICM Insight controllers and ICS software
- Excellent durability
- Compact, lightweight, and high-speed designs
- Easy to use interfaces allow the operator to focus on the job, not the tool — including bright LED headlights and status indicator lights, low force actuation and reverse functions, and patented TactAlert that provides tactile feedback to the operator
- ESD-safe and RoHS-compliant model options
- Super durability cables keep life cycle costs low
- Comfortable, ergonomically contoured grips enhance operator comfort
- Complete line of accessories to maximize productivity



## Handheld tools

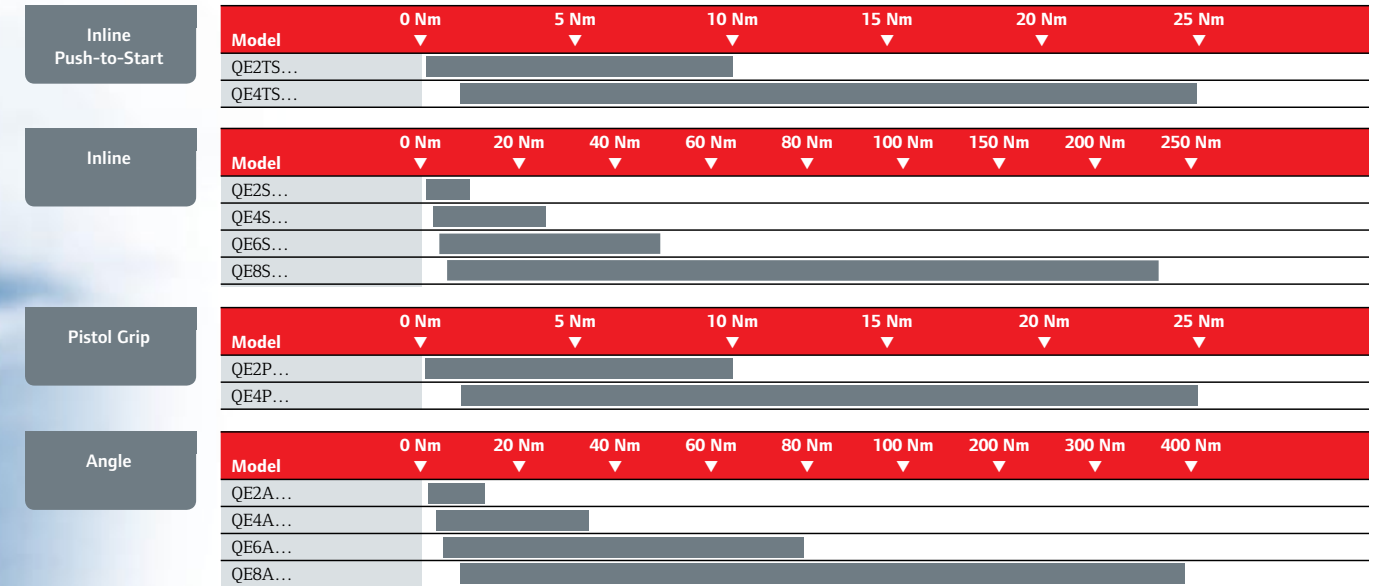

## Fixtured tools

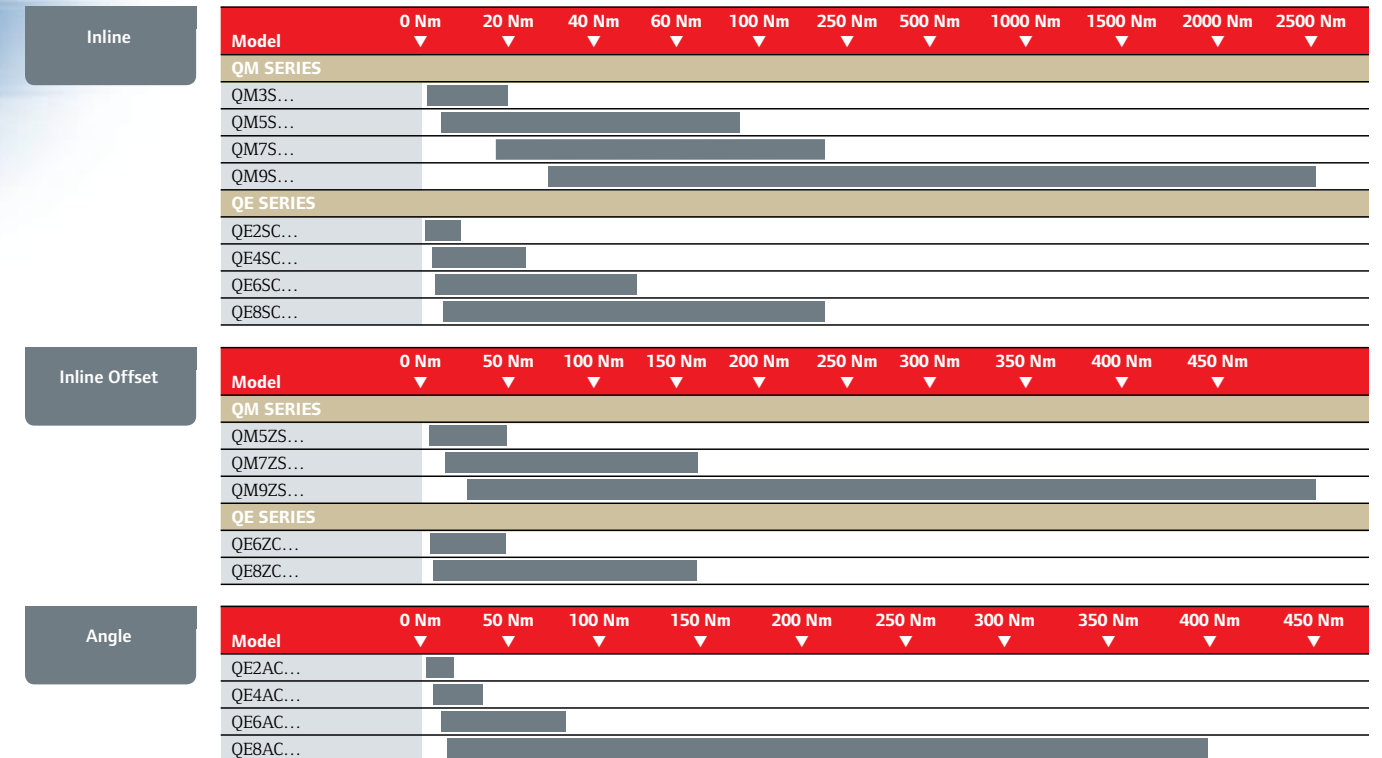

Refer to Assembly Tool catalog, IRPS-1007-052, or irtools.com for a complete list of models and specifications.

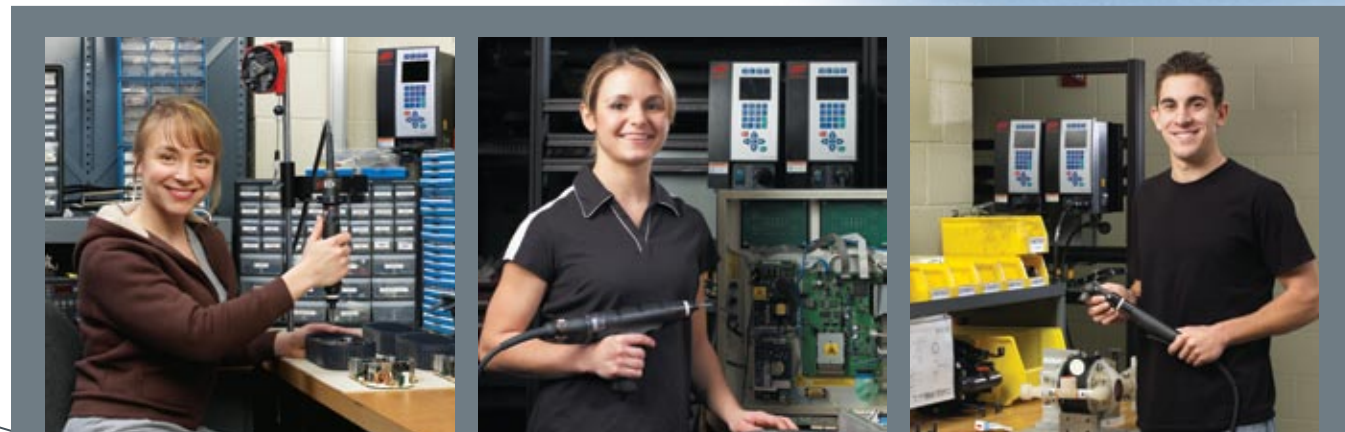

We design our tools with the end user and your bottom line in mind. Keeping the operator happy is one key factor in making your line run efficiently. But we don't stop there. Our feature-rich line of tools provides best-in-class performance and cost-effective solutions to meet your critical fastening requirements.

All Ingersoll Rand tools are designed with durability in mind and are tested to the extreme to prove it. We drop, flex, torque, shock, and literally abuse the tools for millions of cycles to ensure that whatever the real world throws at them, our tools will perform to the same high standards as they do on day one.

All QE Series tools offer the performance and ergonomics operators love. Our commitment to the highest quality products means your operators will focus on the workpiece and forget about the tool.



# Tools

## QE4 / 6 / 8 Series

QE4 / 6 / 8 Series handheld and fixtured tools take productivity, ergonomics, and reliability to new levels. With angle, inline, pistol, push-to-start, and offset configurations, three motor platforms, and torque coverage to 400 Nm, the QE Series tools are engineered for enhanced productivity with impressive features. When matched with an ICD or ICM controller and ICS software, the QE Series will take your operations to the next level.

### Features

- Torque coverage from 1 to 400 Nm
- Full closed-loop transducerized control delivers excellent capability and traceability
- Seamlessly runs on either ICD or ICM controllers
- Compact, high-speed, easily accessible controls
- Easy-to-use reverse ring
- Comfortable ergonomic grips
- Bright LEDs provide visible status indicators
- Highly configurable platform allows users to select output torque, body style, and spindle type to create the perfect tool for the application
- An onboard sensor monitors the motor temperature and protects the unit from excessive heat
- Advanced tightening strategies
- Preventive maintenance alerts

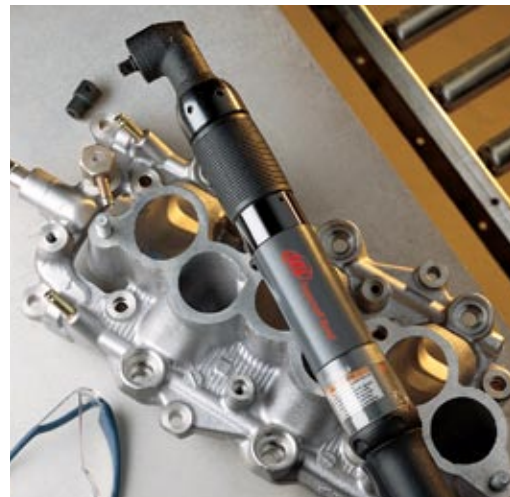

### QE Series DC electric nutrunners

Series	Motor	Body Style	Tool Activation	Maximum Torque (Nm)	Mounting Output	Drive
QE	4 6 8					
		QE4	QE6	QE8	Angle	Q04 = 1/4" Quick Change
		Angle	Angle	Angle	A2 = Size 2 Anglehead	H04 = 1/4" Internal Hex
		013	030	065	A4 = Size 4 Anglehead	S04 = 1/4" Square
		020	040	070	A5 = Size 5 Anglehead	S06 = 3/8" Square
		027	055	090	A6 = Size 6 Anglehead	S08 = 1/2" Square
		034	080	115	A7 = Size 7 Anglehead	S12 = 3/4" Square
				150	A8 = Size 8 Anglehead	
				225	Inline / Pistol	
				400	10 = Pistol Solid	
		Inline	Inline	Inline	11 = Push to Start, Trigger Permit	
		010	020	055	20 = 50 mm Spindle, no float	
		015	028	070	21 = 50 mm Spindle, 19 mm float	
		020	033	090	41 = 100 mm Spindle, 19 mm float	
		025	050	150	61 = 150 mm Spindle, 38 mm float	
				230	81 = 200 mm Spindle, 38 mm float	
					62 = 150 mm Spindle, 50 mm float	
					82 = 200 mm Spindle, 50 mm float	
					02 = 250 mm Spindle, 50 mm float	
					22 = 300 mm Spindle, 50 mm float	

**A** = Angle  
**S** = Inline  
**T** = Inline (Push to Start)  
**Z** = Offset  
**M** = Motor  
**P** = Pistol  
**T** = Trigger  
**L** = Lever  
**E** = Extended Lever  
**P** = Trigger + Push  
**S** = Push to Start  
**C** = Remote Start  
**P** = Standard Gearcase  
**F** = Flanged Gearcase  
**R** = Reaction Bar  
**B** = Bolt on Flange, 1pc.  
**J** = Bolt on Flange, 2pc.



**True closed-loop transducerized control provides exceptional accuracy and traceability**  
**Non-contacting switches, heavy-duty gear train, and brushless DC motor provide exceptional reliability**  
**Ideally positioned, easy-to-use reverse ring**  
**Available with trigger, lever, push-to-start, trigger/lever permit, and remote start actuation options**  
**Multiple drive and head size options**  
**Bright LED headlight illuminates work area**  
**Preventive maintenance alarms**  
**Ergonomically contoured grips enhance operator comfort**  
**Offset heads available for tight clearance applications**  
**Configured solutions available to meet your needs including crows foot, tube nut, and other geared offset heads**  
**Compatible with all ICD and ICM controllers and ICS software**  
**Complete line of accessories available to enhance your productivity**  
**Advanced tightening strategies**  
**High temperature motor protection**  
**Programmable momentary switch**  
**TactAlert provides positive tactile operator feedback without distraction from the task at hand**  
**High durability cable and connections keep lifecycle costs low**  
**Clevis attachment allows for easy connection to torque arms while offering the operator optimal hand positioning and workpiece visibility**  
**Multicolored status indicator lights provide OK / NOK signals**  
**Compact, lightweight, high-speed designs with easily accessible controls**  
**Sculpted hand rest helps reduce operator fatigue**  
**Pistol, inline, angle, offset and motor configurations available**

# Tools

## QM Series

QM Series tools are the workhorse of your multispindle application. With four platforms that provide broad torque and speed coverage, Ingersoll Rand QM spindles deliver at the highest levels of performance, durability, and reliability in the industry. The QM3, QM5, QM7, and QM9 platforms are so durable, in fact, that we stopped testing them after three million fault-free cycles.

### Features

- Torque coverage from 0.8 to 2500 Nm
- Full closed-loop transducerized control delivers better than five percent capability across all four motor platforms
- Highly durable with little preventive maintenance required
- Seamlessly runs on either ICD or ICM controllers
- Flexible mounting options include front-mounting or sandwich-mounting for any unit
- External electronics pod simplifies mounting and connectivity
- Highly configurable platform allows users to select output torque, body style, and spindle type to create the perfect tool for the application
- An onboard sensor monitors the motor temperature and protects the unit from excessive heat
- Easy to service — no special tools required



### QM Series DC electric fixtured spindles

Series	Motor	Body Style	Sensor	Maximum Torque (Nm)	Spring Tension	Spindle	Drive
QM	3	S = Inline	Q03	008	520	62	S06 = 3/8" Square
	5	M = Motor	Q05	035	650	92	S08 = 1/2" Square
	7	Z = Offset	Q07	050	1000	150	S12 = 3/4" Square
	9	S = Single Transducer	Q09	090	1500	225	S16 = 1" Square
					1750	300	
					2000		
					2200		
					2500		



**True closed-loop transducerized control provides exceptional accuracy and traceability**

**Heavy-duty gear train and brushless DC motor provide exceptional reliability and durability**

**Torque ranges from 0.8 to 2500 Nm**

**Better than five percent capability across all four motor platforms**

**Multiple drive and spindle length options**

**Available with or without spindles**

**Compatible with all ICD and ICM controllers and ICS software**

**Offset heads available for tight clearance applications**

**Preventative maintenance alarms**

**Advanced tightening strategies**

**High temperature motor protection**

**High durability cable and connections keep lifecycle costs low**

**Compatibility with Quick Multiple systems that allows fast quoting and delivery of common multispindle systems (see brochure IRITS-1107-043 for details)**

**Complete line of accessories available to enhance your productivity**

**Flexible mounting options include front-mounting or sandwich mounting for any unit**

**Solid, heavy or light spindle spring options**

**External electronics pod simplifies integration**

**Custom Multiples are engineered systems designed and built to your unique requirements**

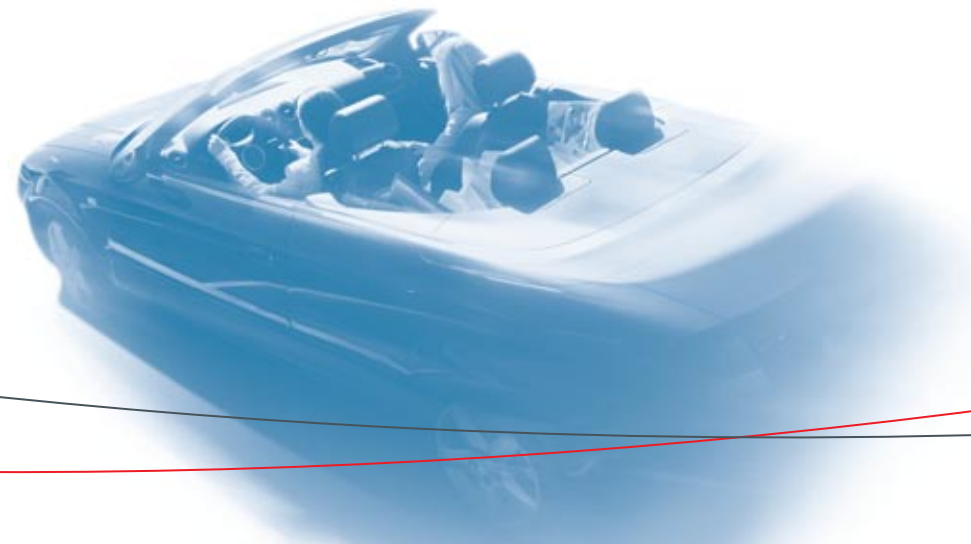

# Controllers

**Insight IC Series controllers** are powerfully precise, fully programmable, and can be seamlessly integrated with any QE or QM Series tools to deliver real performance advantages. We pack extensive torque and angle control, as well as process management capabilities into a small package. Standard features like Ethernet and I/O connections on every unit mean no hidden charges for maximizing communication to your network and there's no need for expensive hardware keys or back-up units.



## IC1M controllers

The IC1M Insight controller is a basic single line display controller that works with all Ingersoll Rand QE and QM DC electric tools and can be either rack- or cabinet-mounted as a single unit or in groups of up to 40 units for multiple-spindle systems.

- Controller transfer key** enables quick upload, recovery, transfer, and storage of configuration sets
- Dual-mode power supply:** 90 – 120 VAC and 200 – 240 VAC
- One-line digital display** shows torque or angle
- 200 cycles of end-of-run automatic data storage**
- Use ICS Connect** to program and select from 256 user configurations stored in memory
- Internal maximum ambient operating temperatures** of 0° – 60° C (32° – 140° F) ensure reliable use in demanding conditions without risk of overheating
- Standard Ethernet and I/O connections** optimize communication and line integration
- Removable cover** provides easy access to connections and terminals, even when the unit is installed
- Front-mounted cable** allows top-to-bottom stacking of units for multispindle applications
- Easy installation** and setup with a convenient bracketing system
- Extruded aluminum cooling fins**
- Power switch** is enclosed in rubber boot for protection

## IC1D controllers

The IC1D Insight controllers give you full closed-loop control in a compact package. With features like a 1/4-VGA color display and easy, intuitive, quick setup programming, the IC1D provides unmatched performance.

- Standard Ethernet and I/O connections** optimize communication and line integration
- 1,000 cycles of end-of-run automatic data storage**
- Dual-mode power supply:** 90 – 120 VAC and 200 – 240 VAC
- Internal maximum ambient operating temperatures** of 0° – 50° C (32° – 122° F) ensure reliable use in demanding conditions without risk of overheating
- Easy installation** and set-up with convenient bracketing system
- Comfortable and tactile membrane** facilitates easy programming and screen navigation
- Extruded aluminum cooling fins**
- Professional 1/4 VGA 216-color display** is visible from 20 ft (6.1 m)
- Program up to eight basic fastening configurations** and access all 256 stored in memory
- Removable cover** provides easy access to connections and terminals, even when the unit is installed
- Controller transfer key** enables quick upload, recovery, transfer, and storage of configuration sets
- Power switch** is enclosed in rubber boot for protection

Expand the capabilities of the ICM and ICD controllers with ICS software. See page 15.



### IC Series DC electric controllers

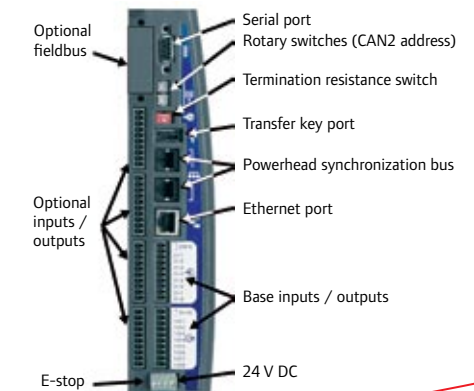
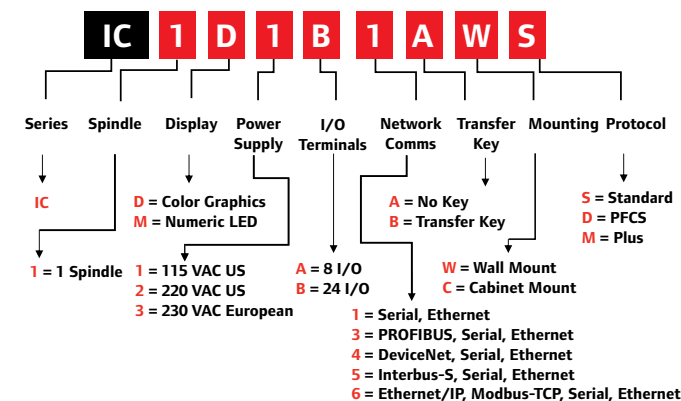

# Controllers

## Insight IC1Display and IC1Module

Measurement torque: Accuracy	±0.2% of torque full scale ±1 count of angle (degrees)
Measurement resolution	±0.025% of torque full scale
Torque transducer bridge excitation	±5V DC/GND
Torque transducer zero offset / drift compensation	±0.4% of full scale
Input signal sensitivity	2.0 mV/V
Calibration	Values read from spindle memory Automatic digital correction
Frequency response (torque filter)	Selectable 75 Hz, 150 Hz, 350 Hz, 500 Hz, 750 Hz
Keypad (IC-D only)	Membrane keypad containing 4 hot keys, 4 function keys, numerical keypad and directional keypad
Display	IC-D: 3.5-inch diagonal, 320 px by 240 px, 8-bit 65K backlit color (QVGA) flat panel display IC-M: 5-character, 7-segment numerical LED display
Parameter sets	256
Number of cycles stored in memory	IC-D: 1,000 IC-M: 200
Communication	Serial RS232, Ethernet, optional PROFIBUS, DeviceNet, Interbus-S, EtherNet / IP, Modbus - TCP
I/O	8 inputs / 8 outputs, with behavior assignable through ISC software: with optional I/O card, an additional 16 inputs and outputs are available
Indicators	Power ON lamp
Input voltage	Single-phase 120 volts, 50/60 Hz, 16 amps Single-phase 230 volts, 50/60 Hz, 8 amps
Ambient operating conditions	0 – 50° C, 20/90% non-condensing humidity
Enclosure	IP-52
System weight	5.6 kg (12.4 lb)
Dimensions (mm)	152 h x 191 w x 23 d

All QE and QM Series tools run on every single controller. Programming is quick and easy and can either be done on-screen (with the ICD), from a computer with ICS Connect, or with the controller transfer key. Having all these features means you'll spend less time on set-up and more time assembling product.



# Software

## ICS software suite

Paired with an Insight IC1D or IC1M controller and a computer, our groundbreaking ICS software suite makes it possible to more precisely control and monitor your fastening process. Optimizing your system is as simple as selecting one of four packages.

### Features

- Four software packages allow you to select the best fit for your requirements
- Compatible with all tools, no exceptions
- Connect, manage, view and program controllers remotely over local area network
- Advanced tightening strategies, including yield control and prevailing torque, improve joint quality
- Generate detailed statistical charts and graphs
- Program and view preventive maintenance alarms, cycle and event logs
- Allows remote monitoring, data collection and data archiving
- View and overlay tightening curves
- Available in Chinese, English, French, German, Italian and Spanish



### Advanced Tightening Strategies

Torque control
Torque control with angle monitoring
Torque control with yield override
Angle control
Angle control with torque monitoring
Angle control with yield override
Yield control
Prevailing torque
Drag torque
Backout
Fault backout
Final fault backout
Retorque
Wait
Jog
Bypass



## Custom software

*Engineered to your unique specifications*

Ingersoll Rand also develops custom software to meet the specific needs of our customers. Whether you need to link data from our controllers into your factory control system, download to a special database or need another customized software solution, our experienced team of software engineers and project managers have the capabilities to get the job done. Our installed base of custom software, running at facilities across the globe, handle local requirements for process line control, quality analysis, data archiving, special printing and many other unique needs.

# Software

## ICS Connect

ICS Connect provides operators the ability to access and program basic fastening strategies, as well as view cycle data with a single IC1D or IC1M controller via a one-to-one Ethernet connection. ICS Connect is supplied standard with all IC1D and IC1M controllers.

### Features

- Enables access to and basic programming of all 256 configurations on IC1D and IC1M controllers
- Provides the primary means of programming an IC1M controller
- Provides quick functionality setup for single-step torque and angle strategies on the IC1D and IC1M controllers
- Captures cycle log, event log, and statistical data
- Enables runtime viewing of fastening data with live screen updating

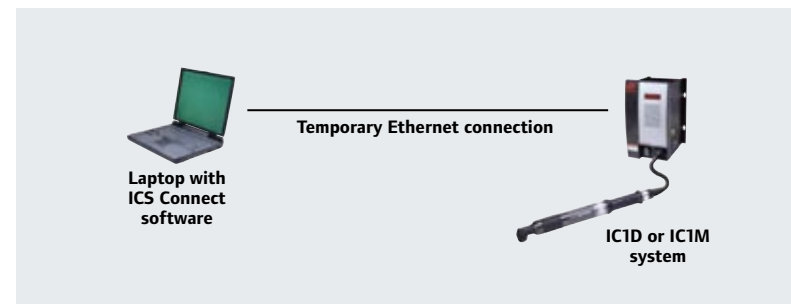

## ICS MultiSync

ICS MultiSync facilitates setup and control of multiple spindle systems consisting of up to 100 spindles in groups of up to 40 spindles. This versatile package offers advanced multiple-spindle fastening strategies such as fault back-out, as well as remote monitoring and data archiving.

### Features

- Programs all regular and powerhead tightening strategies within IC1D and IC1M controllers
- Enables programming and synchronization of up to 100 connected QE Series tools or QM Series spindles
- Enables advanced multispindle strategies such as back-out, fault back-out, final fault back-out, and torque recovery
- Programs and synchronizes spindles to function without software intervention
- Archives tightening data to an internal data table when running in stand-alone powerhead mode
- Collects and supplies data as required when used with ICS Enterprise
- Archives data for all spindles connected

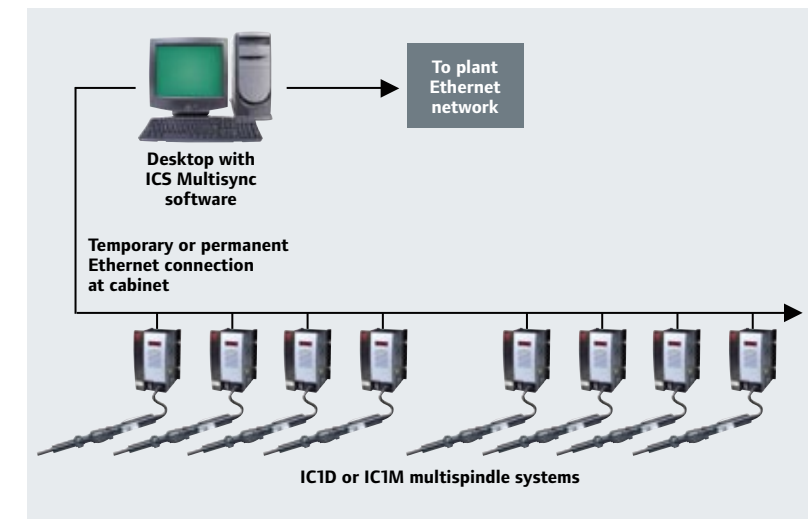

## ICS Network

ICS Network enables programming of multiple IC1D and IC1M controllers connected through a local area network (LAN) or direct connection. This option also allows operators to program advanced fastening strategies including yield and prevailing torque control.

### Features

- Allows operators to connect, manage, view, and program up to 500 IC1D or IC1M controllers (depending on license) through a local area network
- Enables programming of advanced multistep tightening strategies including drag torque and prevailing torque on IC1D and IC1M controllers
- Activates the innovative TactAlert capability of QE Series tools
- Generates detailed statistical charts and graphs
- Enables viewing of a single tightening curve
- Programs preventive maintenance (PM) alarms
- Enables "stats alarms" function
- Provides bar code and field bus interfaces

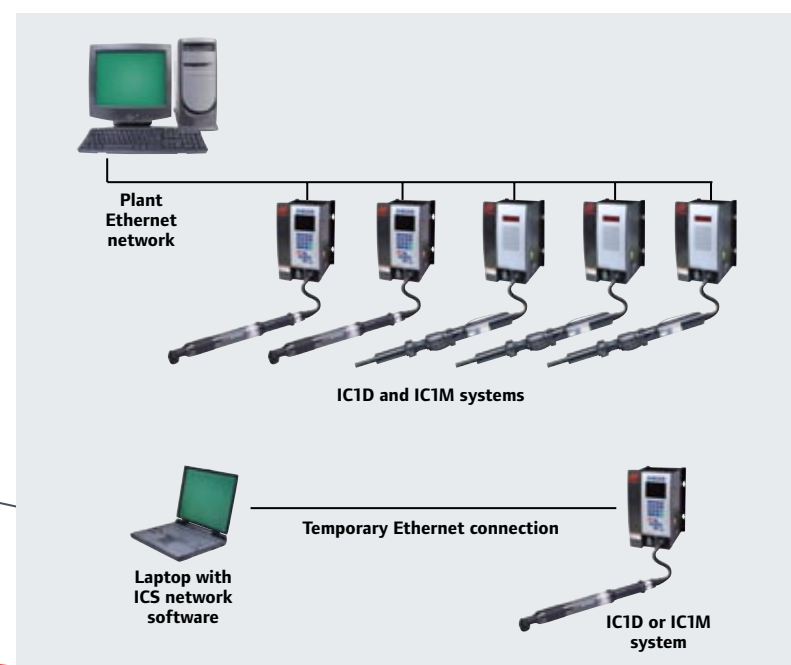

## ICS Enterprise

ICS Enterprise offers advanced programming and management of a network of up to 500 IC1D and IC1M controllers using QE, QM, and multiple-spindle systems. This package includes all elements of ICS MultiSync and SQL Server database archiving, searching, and statistics processing.

### Features

- Provides all of the functionality of ICS Connect, ICS Network, and ICS MultiSync
- Offers advanced programming and network management of up to 500 IC1D or IC1M controllers with QE Series tools, QM Series spindles, or multispindle systems (depending on license)
- Enables output of data to SQL Server database to archive cycle data, curves, parameter settings, diagnostics, event logs, and statistics
- Schedules regular archiving based on time or number of cycles
- Enables data sorting, searching, and reporting by shift, tool ID, VIN, and more
- Provides 10-curve, on-screen tightening curve overlay

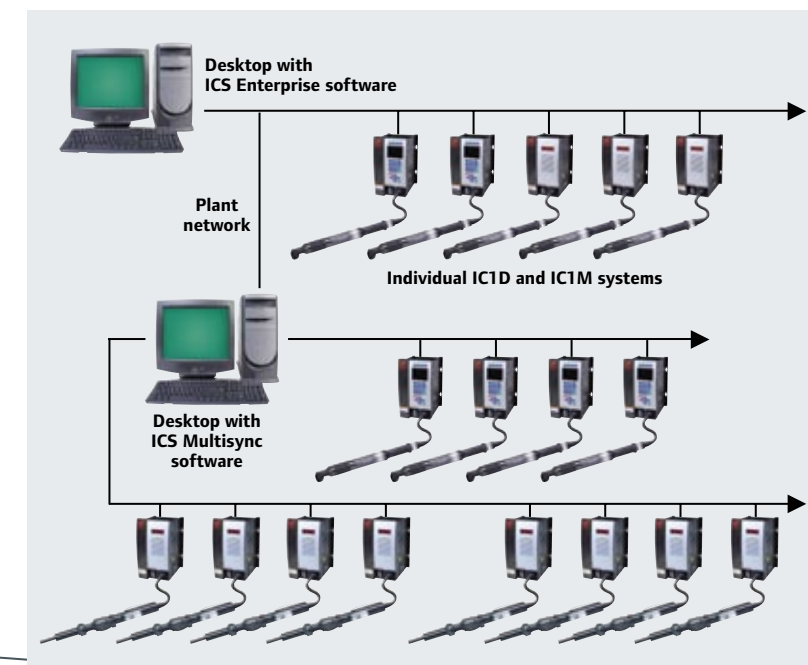

# Quick multiples

Modular designs, flexible solutions

**Quick multiples** consist of pre-engineered modular component designs that allow quick quoting, manufacture, and delivery of more common fixtured fastening solutions for up to six spindles. Depending on the application, vertical, horizontal, or rotating horizontal systems can be assembled with easily customized handles, displays, fixtures, and integrated handling devices for optimal operator ergonomics and performance.

**Modular design** provides for easy customization of open- or closed-frame fixtures in vertical, horizontal, or rotating horizontal configurations

**Mounts** are available in several options that adjust to give operators the most ergonomic position, visibility, and control possible

**Handle module** provides multiple switch options based on the application

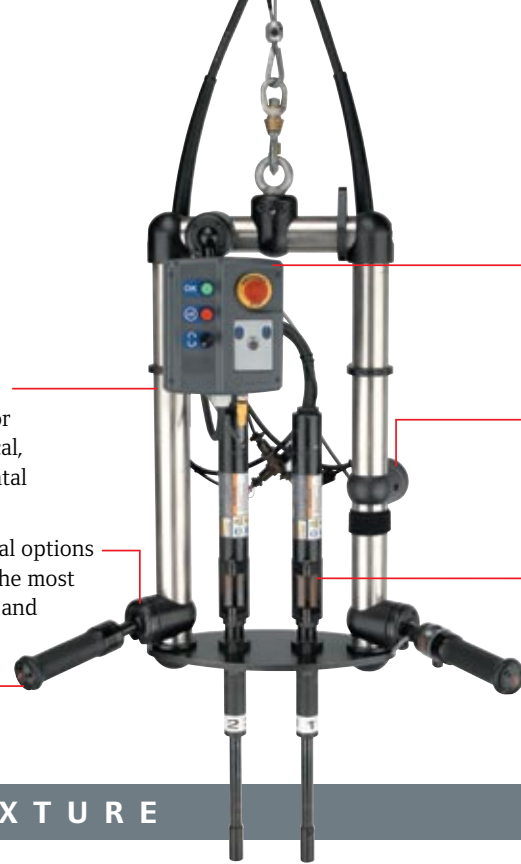

**Customizable interface** provides the control and feedback you desire. Standard LED display shows individual spindle and master OK / NOK signals.

**Modular design** offers flexibility for easy customization, rapid quotes, and lead-times.

**World-class tools** deliver accuracy and durability to maximize your line's productivity.

- QM and QE Series
- QA4 / 6 / 8 Series

**Cable tray** provides secure routing path, which keeps cables safe and out of the way, and reduces sharp bends.

**Multiple suspension and torque reaction** options:

- Balancers
- Torque tubes
- Articulating arms
- Custom devices
- Jib cranes
- Pneumatic suspension

**Heavy-duty bearing** delivers smooth rotation and adjustable stops for up to six spindles and provides for an ideal cable exit.

**Circular handle** allows rapid positioning of sockets on bolts.

**Mounting plates** can be quickly and easily machined to the exact job specifications.

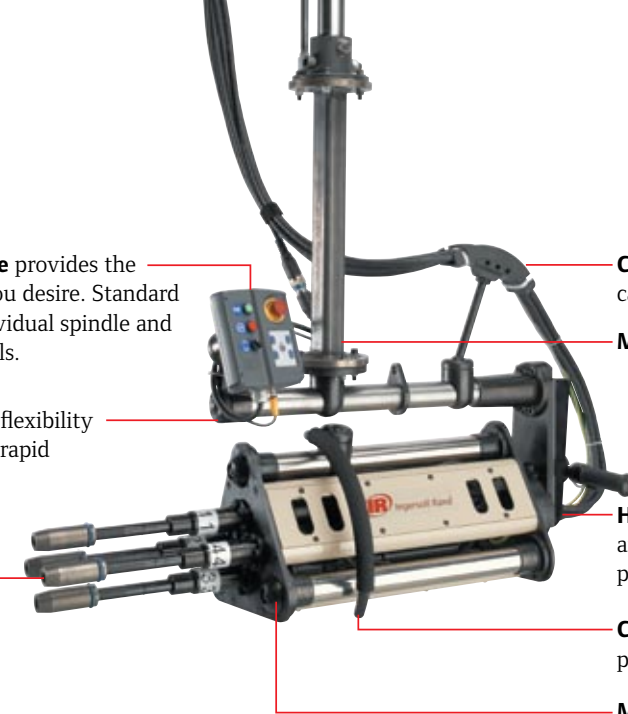

VERTICAL AND HORIZONTAL FIXTURE

ROTATING HORIZONTAL FIXTURE

## Interface module

The **Interface's** modular design provides for easy customization to meet your needs. The module comes standard with a configurable LED display to match your bolt pattern, an E-Stop switch, label kit, and enclosure assembly, and can be customized with any four of the six additional display and control options to suit your application.

**Modular design** provides flexibility for easy customization.

**Additional options** include:

- Push button
- 2-position switch
- 3-position switch
- 3-position key switch
- Red and green lamps
- Buzzer

**Standard module** includes:

- Enclosure and PCB
- E-Stop, whip cable
- LED display, label kit



Durable metal reinforced composite enclosure.

Standard E-stop.

Standard LED display shows individual and master OK / NOK signal for up to six spindles, and can be organized to match bolt pattern.

Flexible design provides for panel, tube, or ball joint mounting.

Flexible design allows cable exits from top, bottom, sides, or back of enclosure.

Refer to *Fixtured Fastening System* brochure, IRITS-1107-043, for detailed specifications.

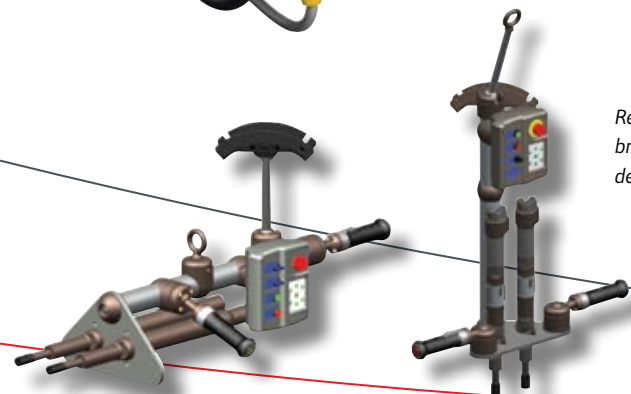
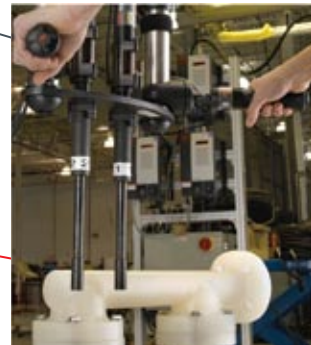

## Handle module

The **Handle's** modular design provides the flexibility to order exactly what you need for your job. Whether you need to outfit your fixture with trigger or slide-electronic switching, pneumatic control, or only a dead handle, we offer the solution to fit your application.

Actuation options include:

- Trigger, slide switch, or both
- Pneumatic
- Dead handle (none)

Slide switch can be configured as momentary or detent style.

Ball, flange, or direct mounting options allow optimal handle orientation with the operator.



20 possible configurations deliver the exact combination needed.

Ergonomic grip provides both comfort and durability.

Trigger and slide switch can be aligned (shown left) or rotated 90 degrees based on desired hand positioning.

## Custom multiples

Engineered to your unique specifications

**Custom engineered** fixtured fastening systems are available for more complex jobs with requirements such as adjustable bolt centers, more than six spindles, specialized clamping, indexing, custom fixture design, and automation.

Ingersoll Rand's worldwide network of solution centers can serve your "Rail-to-Floor" project requirements from start to finish. Our full-range offering starts with joint analysis and process audits, and spans system design, project management, installation, and after-sales support.



# QTA torque arms

Ingersoll Rand offers an impressive line of ergonomic torque reaction arms that help operators work more safely and comfortably while maximizing efficiency, to ensure product quality and minimize downtime. See the full QTA torque arm brochure (IRPS-0907-044) for a complete listing of torque arm products and specifications.



**360-degree rotation** adds greater flexibility (models up to 100 Nm)

**Spring balancer** adjusts easily and offers effortless vertical movement

**Simple, proven design** for trouble-free setup and dependability

**Anodized aluminum body** delivers durability in a lightweight design

**Adjustable reach** for ease of use and convenience

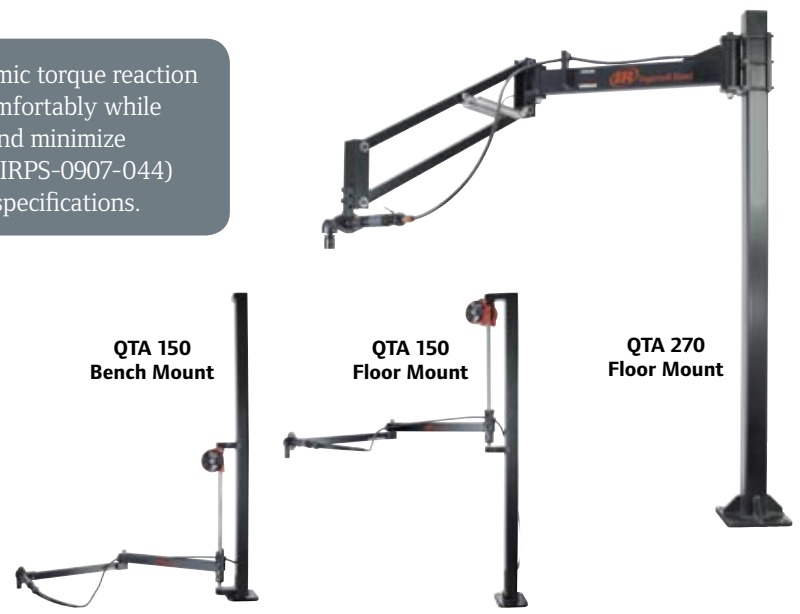

**QTA 150 Bench Mount**

**QTA 150 Floor Mount**

**QTA 270 Floor Mount**

The QTA150 can be easily configured as either a bench-mounted or floor-mounted torque arm, and reconfigured as the job demands

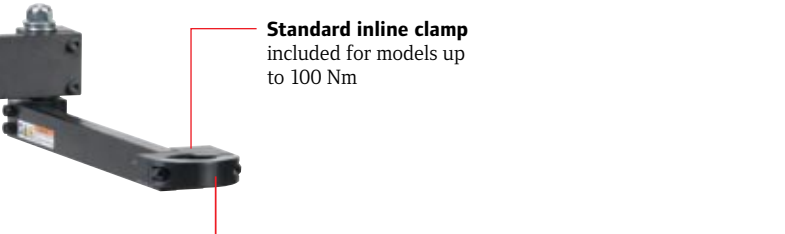

**Standard inline clamp** included for models up to 100 Nm

**Multiple tool holder options**

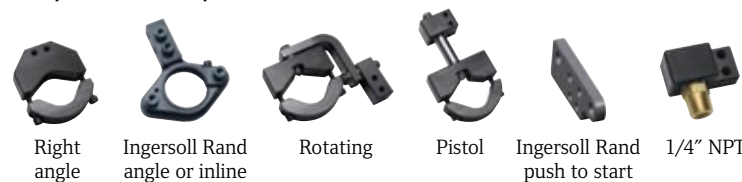

Model	Max Torque (ft-lb) Nm	Max Weight Capacity lb (kg)	Max. Working Reach in (mm)	Approx. Vertical Travel in (mm)	Overall Height in (mm)
QTA010	7.4 (10)	2.64 (1.20)	15 (381)	13.0 (330)	27.8 (706)
QTA020	14.8 (20)	5.00 (2.27)	20 (508)	14.5 (368)	31.8 (808)
QTA040	29.5 (40)	6.50 (2.95)	25 (635)	17.5 (445)	39.7 (1008)
QTA100	73.8 (100)	8.00 (3.63)	30 (762)	17.5 (445)	39.7 (1008)
QTA150	110.6 (150)	10.00 (4.54)	52 (1321)	22.0 (559)	78.7 (2000)
QTA270	199 (270)	22.00 (10.00)	60 (1524)	18.8 (477)	78.7 (2000)
QTA475	350 (475)	50.60 (23.00)	79 (2007)	23.2 (590)	78.7 (2000)

**QTA100-10 Bench Mount**

# Global support

## Productivity beyond product

When you work with Ingersoll Rand, you get Productivity Beyond Product. Our experts know assembly environments inside and out, and we have the sales, engineering, and service teams in place around the world to deliver a local solution tailored to your unique operational needs.

Our 360-degree approach to maximizing your productivity includes world-class auditing, products, integration, and service in all areas of the assembly process. It's an integrated approach that will not only meet your needs, but exceed your expectations.

### Audits

Ingersoll Rand consultants can spend time with you, observing and auditing the layout, ergonomic design, and productivity of your assembly process. Our service and sales teams are uniquely qualified to assess your individual applications and recommend solutions that make sense for you. You can also take advantage of our best-in-class joint consulting capabilities by sending your components and fasteners to one of our application labs. We'll recommend a fastening strategy that gives you the clamp load you need and the quality your customers demand.

- ▶ Application testing
- ▶ Systems capability study
- ▶ Ergonomic audit

### Products

Innovative products are the core of our integrated "rail-to-floor" approach. From world-class DC electric fastening tools, controllers, and software to ergonomic handling systems, our product portfolio spans the full fastening continuum to provide you with the best technology for your application. Add calibration equipment and choose from our full line of accessories including user interfaces, cabinets, cables, selector switches, and sockets to complete your system design.

- ▶ World-class tools
- ▶ World-class controllers
- ▶ World-class software
- ▶ World-class ergonomic handling

### Integration

Our extensive knowledge of systems integration makes connecting your new equipment to your existing facilities a seamless process. The Ingersoll Rand service team has years of experience in program management, custom networking and software, PLC programming, and line integration — exactly the combination you need to get up and running.

- ▶ Installation support
- ▶ Acceptance testing
- ▶ System commissioning
- ▶ Networking and programming
- ▶ Financing

### Service

Want to minimize downtime? No problem. Ingersoll Rand provides unmatched customer service, and a variety of services to keep you running at your peak productivity — from installation and training to preventive maintenance, calibration, and repairs.

- ▶ Operator and skilled trades training
- ▶ Calibration and repair
- ▶ Preventive maintenance contracts
- ▶ Refurbishment programs
- ▶ Global network coverage



**Russia**  
Ingersoll Rand Company  
Pavlovo ul. Chapaeva, 43  
Nizhegorodskaya Oblast, 606130, Russia  
Telephone : 7 83171 61486

**France**  
Ingersoll Rand Company  
70, rue Jacquard  
77400 Lagny sur Marne, France  
Telephone: +33 1 64 76 00 00

**North America**  
Ingersoll Rand Company  
1872 Enterprise Drive  
Rochester Hills, MI 48309, USA  
Telephone: (248) 293-5700

**Mexico**  
Ingersoll Rand Company  
Boulevard Centro Industrial No. 11  
Industrial Puente de Vigas  
54070 Tlalnepantla, México  
Telephone: +52 (55) 8503 6600

**India**  
Ingersoll Rand Industrial Products Pvt. Ltd.  
37-A, Site-4, Sahibabad Industrial Area  
Ghaziabad-201010, India  
Telephone: +91 (0)120-2895116

**China**  
Ingersoll Rand Company  
335 Lv Chun Road  
Minhang Industrial Zone  
Shanghai 200245, P.R.C.  
Telephone: 86-21-6463 8018

# Accessories and literature

## Controller accessories

Part Number	Description
IC-PALM-RESET	Palm button reset station
IC-ESTOP	Emergency stop button
IC-LIGHT-TOWER	Light tower
3002007	Wall mounting bracket for IC1D/M
3002010	Cabinet mounting bracket for IC1D/M
IC-SELECT-2	2-position remote selector switch
IC-SELECT-4	4-position remote selector switch
IC-SELECT-6	6-position remote selector switch
PC80150113	Controller transfer key

## Angle head boots

	A2 & A3	A4	A5	A6	A7
Standard	GEA40-171	GEA40-172	GEA40-172	GEA40-173	GEA40-173
Extended	GAA2-170	GAA4-170	GAA5-170	GAA6-170	GAA7-170

## Lever kits

Part Number	Description
GEA40-K98SL	Short lever kit
GEA40-K98EL	Extended lever kit

## Hanging and mounting accessories

Part Number	Description	For Use With
GEA15-K364	Swivel hanger kit	QE4
GEA40-K364	Swivel hanger kit	QE6 & QE8
CPS2-A365	Angle tool hanger	QE2 Series
7L-365	Suspension bail	All QE Series
CPS2-48	Pistol reaction Bar	QE2 Series
GEA15-K48	Reaction bar kit	QE4, QA4 inline up to 27 Nm
GEPTS15-K48	Reaction bar kit	QE4TS
DEA120-K48	Reaction bar kit	QE6 & QE8, QA4 inline 46 Nm
15E4-K48	Flanged mounting kit	QE4, QA4 / QA8 inline up to 55 Nm, angle up to 55 Nm
GEM120-K48	Flanged mounting kit	QE6 & QE8, QA6 / QA8 inline 70 / 90 Nm, angle 115 / 150 Nm
GEA4-K48	Mounting plate kit	QE4, QA6 / QA8 inline up to 55 Nm, angle up to 90 Nm
DAM120-K48	Mounting plate kit	QE6 & QE8, QA6 / QA8 inline 70 / 90 Nm, angle 115 / 150 Nm
SBB4-QE2	Bio brace	QE2 Series

## Bit and socket trays and accessories

Part Number	Description
IC-BIT-8	8-position bit tray
IC-SOCKET-4	4-position socket tray
IC-SOCKET-8	8-position socket tray
IC-10PIN-6M	6 m cable for 4-position tray
IC-10PIN-10M	10 m cable for 4-position tray
IC-19PIN-5M	5 m cable for 8-position tray
IC-19PIN-10M	10 m cable for 8-position tray
GEA15-38KIT-5	3/8" socket pin kit
GEA40-12KIT-5	1/2" socket pin kit
IRPS-0506-016	Impact socket brochure



Palm reset



Emergency stop



Light tower



Angle head boots



Lever kit



Flange mounting kit



Mounting plate kit



Swivel hanger kit



Bio brace



4-position socket tray



Impact sockets

## Cable accessories

Handle Module Extension Cables	(2 m)	(4 m)	(6 m)
Handle extension cordset	QMMC-46-2M	QMMC-46-4M	QMMC-46-6M
Interface Module Cables			
Interface extension cable (10 m)			QMMC-A240-10
Interface extension cable (20 m)			QMMC-A240-20
Powerhead cable (2 m)			QMMC-A240-2
DC Tool Cables	(3 m)	(6 m)	(10 m)
Tool cable (QE2)	GPS2-CORD-3M	GPS2-CORD-6M	GPS2-CORD-10M
90° tool cable (QE2)	—	GPS2-CORD-6M-90	—
Tool cable (QM, QE4/6/8)	GEA40-CORD-3M	GEA40-CORD-6M	GEA40-CORD-10M
90° tool cable (QM, QE4/6/8)	GEA40-CORD-3M-90	GEA40-CORD-6M-90	GEA40-CORD-10M-90
DC Tool Extension Cables	(10 m)	(20 m)	(40 m)
Extension cable	GEA40-EXT-10M	GEA40-EXT-20M	GEA40-EXT-40M
	(50")	(60")	(70")
90° extension cable	GEA40-INT-01	GEA40-INT-02	GEA40-INT-03
	(80")	(90")	(100")
90° extension cable	GEA40-INT-04	GEA40-INT-05	GEA40-INT-06
	(110")	(120")	(130")
90° extension cable	GEA40-INT-07	GEA40-INT-08	GEA40-INT-08

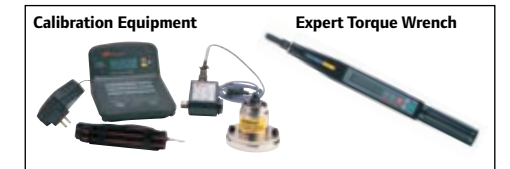

## Calibration equipment

EXPERT TORQUE WRENCH				
	ft-lb (Nm)		in	
ETW-E25	18 (25)		1/4"	
ETW-E75	40 (55)		3/8"	
ETW-E180	133 (180)		1/2"	
ROTARY TRANSDUCERS				
Industry Standard*	"Smart" Torque	"Smart" Torque & Angle	in-lb (Nm)	in
TR2H4	—	—	1.0 – 18 (0.10 – 2)	1/4"
TR5H4	TRD5H4	TRDA5H4	2.2 – 44 (0.25 – 5)	1/4"
TR20H4	TRD20H4	TRDA20H4	9.0 – 180 (1 – 20)	1/4"
TR20S4	TRD20S4	TRDA20S4	9.0 – 180 (1 – 20)	1/4"
TR75S6	TRD75S6	TRDA75S6	2.8 – 55 (3.8 – 75)	3/8"
TR180S8	TRD180S8	TRDA180S8	6.7 – 133 (9 – 180)	1/2"
TR250S12	—	—	9.2 – 185 (12.5 – 250)	3/4"
TR500S12	TRD500S12	TRDA500S12	18.5 – 370 (25 – 500)	3/4"
STATIONARY TRANSDUCERS				
Stationary Transducer	"Smart" Transducers	ft-lb (Nm)	in	
TS30S4	TSD28S4	1.1 – 22 (1.5 – 30)	1/4"	
TS150S6	TSD135S6	5.5 – 110 (7.5 – 150)	3/8"	
TS300S8	TSD270S8	11 – 221 (15 – 300)	1/2"	
TS1000S12	TSD1000S12	37 – 738 (50 – 1000)	3/4"	

\*Industry-standard transducers require ETA2-TC cable.

## Literature

Catalog Name	Form Number	Catalog Name	Form Number
QA4/6/8 air tools	IRPS-1007-053	Torque arms	IRPS-0907-044
Impact screwdriver	IRITS-1107-044	Pulse tools	SW041107
Audit wrench	ASM-1106-128	Fixture fastening	IRITS-1107-043
Assembly tools	IRPS-1007-052	Cordless tools	VSS-0806-060
Feed drill	52475-AT-C	Ergonomic handling	MHD55226

To order Ingersoll Rand literature please e-mail: [irlitorders@kencook.com](mailto:irlitorders@kencook.com)

## Suspension and reaction devices

TORQUE TUBES					
See literature listed below for more details					
Model	Description	Lift Capacity @100 psi lb (kg)	Torque Capacity lb (kg)	Vertical Travel in (mm)	Weight lb (kg)
54044227	IRZ-TT-100	60 (27)	74 (100)	20 (508)	40 (18)
54041819	IRZ-TT-250	60 (27)	184 (250)	24 (610)	50 (23)
54044417	IRZ-TT-500	400 (182)	368 (500)	36 (914)	75 (75)
BALANCERS					
See literature listed below for more details					
Model	Type	Lift Capacity lb (kg)	Vertical Travel in (m)	Weight lb (kg)	
BLD Series	Spring	0.9-6.6 (0.4-3.3)	5.2 (1.6)	1.3-1.5 (0.6-0.7)	
BMD Series	Spring	2.2-22 (1-10)	6.5-8.2 (2-2.5)	4.4-8.8 (2-4)	
BHD Series	Spring	22-143 (10-65)	6.5 (2.0)	23-30 (10-14)	
BSD Series	Spring	33-363 (15-165)	8.2 (2.5)	42-106 (19-48)	
BSDL Series	Spring	33-330 (15-150)	9.8 (3.0)	42-100 (19-46)	
BA/ZA Series	Pneumatic	up to 2000 (907)	up to 120 (3.0)	up to 225 (102)	

