

REV **D**

**S-3396**

DRAWING NO.

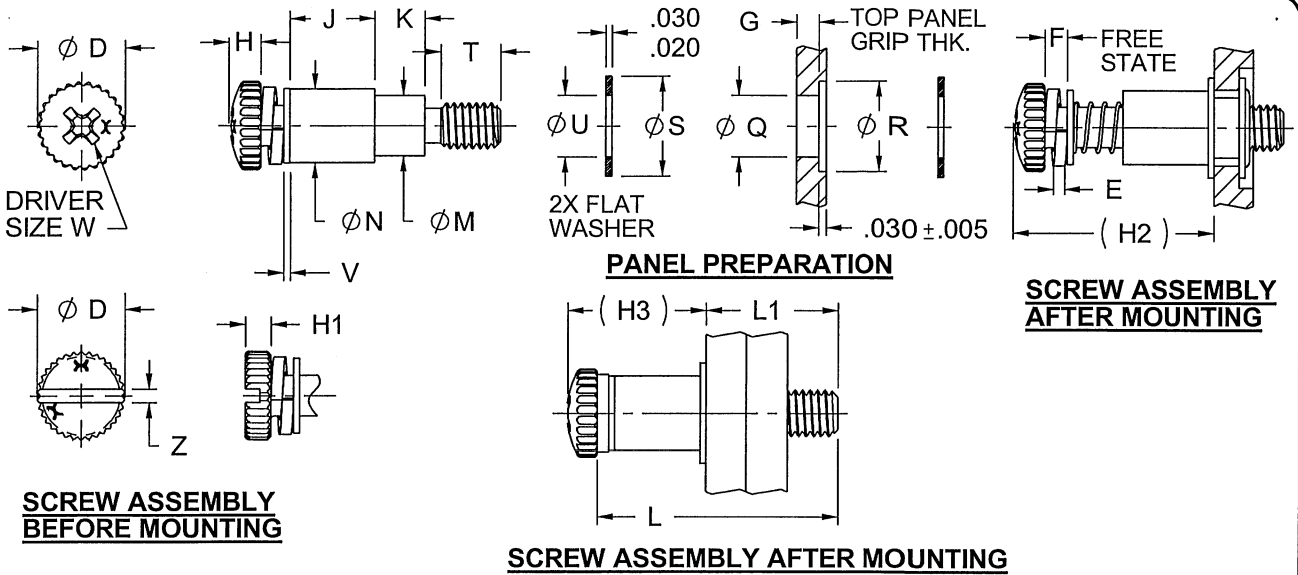

**ORIGINAL**  
 Red Ink Indicates  
 Original Copy

| THREAD SIZE CODE | ØD   | E ±.005 | F    | H    | H1   | (H2)  | (H3) | J    | ØM ±.005 | ØN ±.010 | ØQ +.004 - .001 | ØR +.020 - .000 | ØS ±.010 | T | ØU +.004 - .001 | V ±.005 | W | Z    |
|------------------|------|---------|------|------|------|-------|------|------|----------|----------|-----------------|-----------------|----------|---|-----------------|---------|---|------|
| 4                | .212 | .025    | .050 | .080 | .068 | 1.020 | .525 | .365 | .178     | .209     | .250            | .390            | .309     | 1 | .185            | .016    | 1 | .040 |
| 6                | .263 | .031    | .062 | .097 | .082 | 1.020 | .525 | .360 | .202     | .250     | .272            | .406            | .333     |   | .209            | .016    | 2 | .044 |
| 8                | .314 | .040    | .080 | .115 | .096 | 1.060 | .565 | .345 | .215     | .300     | .281            | .468            | .385     |   | .223            | .025    | 2 | .049 |
| 10               | .365 | .047    | .094 | .133 | .110 | 1.060 | .575 | .345 | .250     | .312     | .316            | .500            | .415     |   | .257            | .025    | 2 | .055 |
| 12               | .482 | .062    | .124 | .175 | .144 | 1.109 | .722 | .435 | .316     | .437     | .382            | .566            | .495     |   | .323            | .025    | 3 | .062 |

**PART NUMBER CALLOUT**

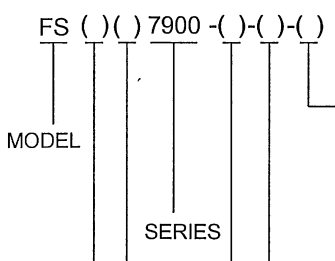

| LENGTH CODE | L           |       | L1 ±.020 | LENGTH CODE | L           |       | L1 ±.020 |
|-------------|-------------|-------|----------|-------------|-------------|-------|----------|
|             | 4, 6, 8, 10 | 12    |          |             | 4, 6, 8, 10 | 12    |          |
| 3           | .750        | .871  | .320     | 6           | 1.125       | 1.246 | .695     |
| 3.5         | .812        | .933  | .382     | 6.5         | 1.187       | 1.308 | .757     |
| 4           | .875        | .996  | .445     | 7           | 1.250       | 1.371 | .820     |
| 4.5         | .937        | 1.058 | .507     | 7.5         | 1.312       | 1.433 | .882     |
| 5           | 1.000       | 1.121 | .570     | 8           | 1.375       | 1.496 | .945     |
| 5.5         | 1.062       | 1.183 | .632     | 8.5         | 1.437       | 1.558 | 1.007    |

| THREAD SIZE CODE | THREAD SIZE PER ASME B1.1 | LEAD   |
|------------------|---------------------------|--------|
| 4                | .112-40 UNC-2A            | SINGLE |
| 6                | .138-32 UNC-2A            |        |
| 8                | .164-32 UNC-2A            |        |
| 10               | .190-32 UNF-2A            |        |
| 12               | .250-28 UNF-2A            |        |

| GRIP CODE | G                          |         |
|-----------|----------------------------|---------|
|           | (TOP PANEL GRIP THICKNESS) | K ±.005 |
| BB        | .020-.031                  | .115    |
| B         | .032-.063                  | .147    |
| C         | .064-.125                  | .210    |
| D         | .126-.187                  | .272    |
| E         | .188-.250                  | .335    |

| CODE | FINISH      |
|------|-------------|
| NONE | BLACK OXIDE |
| U    | PASSVATE    |

| RECESS CODE | DRIVING RECESS AND SPECIFICATION |
|-------------|----------------------------------|
| C           | CROSS RECESS PER NASM 9006       |
| D           | SLOT RECESS PER ANSIB18.6.3      |

THIS DRAWING, THE STRUCTURAL DESIGN DISCLOSED THEREIN, THE TECHNICAL DATA AND ENGINEERING SERVICE REPRESENTED THEREBY ARE THE EXCLUSIVE PROPERTY OF HUCK INTERNATIONAL, INC.

|     |                    |          |
|-----|--------------------|----------|
| D   | DCN 5542           | 07-13-07 |
| REV | DESCRIPTION/EC NO. | DATE     |

UNLESS OTHERWISE SPECIFIED ALL DIMENSIONS IN INCHES

TOLERANCE UNLESS OTHERWISE NOTED:  
 .X = ±.05      ANGLES ±0.5°  
 .XX = ±.02  
 .XXX = ±.015

**Alcoa Fastening Systems**  
 AEROSPACE FASTENER DIVISION  
 3724 EAST COLUMBIA STREET  
 TUCSON, ARIZONA 85714  
 PHONE 520 519-7400  
 FAX 520 519-7427  
 www.alcoafasteners.com

|  |                                       |                 |  |
|--|---------------------------------------|-----------------|--|
| TITLE<br><b>CAPTIVE SCREW, OPTIONAL RECESS, SPRING LOADED, ALL CRES, FULLY RETRACTABLE</b>     |                                       |                 |  |
| DATE<br>11/29/2005   | PART NUMBER<br><b>FS ( ) ( ) 7900</b> |                 |  |
| DRAWN<br>JLS   | DRAWING NO.<br><b>S-3396</b>          |                 |  |
| CHECK<br> | CAGE CODE<br>0HDW7                    | REV<br><b>D</b> |  |
| APPROVE  | SCALE: 1.25:1                         | SHEET 1 OF 2    |  |

**ORIGINAL**  
 Red Ink Indicates  
 Original Copy

REV **D**

DRAWING NO. **S-3396**

DRAWING NO.

THIS DRAWING, THE STRUCTURAL DESIGN DISCLOSED THEREIN, THE TECHNICAL DATA AND ENGINEERING SERVICE REPRESENTED THEREBY ARE THE EXCLUSIVE PROPERTY OF HUCK INTERNATIONAL, INC.

THREAD LENGTH AVAILABILITY TABLES

2

| GRIP CODE | SIZE 4 |      |      |      |      |      |   |
|-----------|--------|------|------|------|------|------|---|
|           | 3      | 3.5  | 4    | 4.5  | 5    | 5.5  | 6 |
| BB        | .161   |      |      |      |      |      |   |
| B         | .128   | .191 |      |      |      | .203 |   |
| C         |        | .128 | .191 |      |      |      |   |
| D         |        |      | .128 | .191 |      |      |   |
| E         |        |      |      | .128 | .191 |      |   |

2

| GRIP CODE | SIZE 6 |      |      |      |      |      |   |
|-----------|--------|------|------|------|------|------|---|
|           | 3      | 3.5  | 4    | 4.5  | 5    | 5.5  | 6 |
| BB        | .149   |      |      |      |      |      |   |
| B         | .117   | .179 |      |      |      | .203 |   |
| C         |        | .117 | .179 |      |      |      |   |
| D         |        |      | .117 | .179 |      |      |   |
| E         |        |      |      | .117 | .179 |      |   |

| GRIP CODE | SIZE 8 |      |      |      |      |      |   |
|-----------|--------|------|------|------|------|------|---|
|           | 3      | 3.5  | 4    | 4.5  | 5    | 5.5  | 6 |
| BB        | .135   | .197 |      |      |      |      |   |
| B         | .103   | .165 | .228 |      |      | .250 |   |
| C         |        | .103 | .165 | .228 |      |      |   |
| D         |        |      | .103 | .165 | .228 |      |   |
| E         |        |      |      | .103 | .165 | .228 |   |

| GRIP CODE | SIZE 10 |      |      |      |      |      |   |
|-----------|---------|------|------|------|------|------|---|
|           | 3       | 3.5  | 4    | 4.5  | 5    | 5.5  | 6 |
| BB        | .121    | .183 |      |      |      |      |   |
| B         |         | .151 | .213 |      |      | .250 |   |
| C         |         |      | .151 | .213 |      |      |   |
| D         |         |      |      | .151 | .213 |      |   |
| E         |         |      |      |      | .151 | .213 |   |

| GRIP CODE | SIZE 12 |      |      |      |      |      |   |
|-----------|---------|------|------|------|------|------|---|
|           | 3       | 3.5  | 4    | 4.5  | 5    | 5.5  | 6 |
| BB        | .197    | .260 |      |      |      |      |   |
| B         | .165    | .228 |      |      |      | .281 |   |
| C         |         | .165 | .228 |      |      |      |   |
| D         |         |      | .165 | .228 |      |      |   |
| E         |         |      |      | .165 | .228 |      |   |

ASSEMBLIES NOT AVAILABLE

\* LENGTH CODES NOT SHOWN ARE AVAILABLE WITH THE LONGER THREAD LENGTH PER APPLICABLE TABLE

INSTALLATION TOOLS:  
( ) = THREAD SIZE CODE

- 3 EXTENSION DT257EN
- ARBOR PRESS TOOL HW7600-( )
- NOSE PIECE HN7513-( )
- PULLER HP7523-( )
- 2 HANDLE ASS'Y TA7533

MATERIAL

- STUD:  
302 CRES PER ASTM-A-493, AMS 5636
- LOCKWASHER:  
300 SERIES CRES PER AMS 5519 OR EQUIV.
- SLEEVE:  
304 CRES PER AMS-QQ-S-763, AMS 5639
- SPRING:  
302 CRES PER ASTM-A-313, AMS 5688
- FLAT WASHERS:  
300 SERIES CRES PER AMS 5519 OR EQUIV.

FINISH

- FSCU 7900 & FSDU 7900:  
PASSIVATE PER AMS-QQ-P-35
- FSC 7900 & FSD 7900:
- SPRING:  
PASSIVATE PER AMS-QQ-P-35
- ALL OTHER COMPONENTS:  
BLACK OXIDE PER MIL-C-13924, CLASS 4.

NOTES:

- 1 SEE APPROPRIATE THREAD LENGTH AVAILABILITY TABLE FOR "T" DIMENSION
- 2 DO NOT USE HAND TOOL ON 4 & 6 THREAD SIZE CODES.
- 3 FOR LONGER STUD/SHORT SLEEVE COMBINATIONS, EXTENSION DT257EN IS RECOMMENDED WITH HAND TOOL
- 4 THIS ASSEMBLY HAS .030 RADIAL FLOAT

|     |                    |          |
|-----|--------------------|----------|
| D   | DCN 5542           | 07-13-07 |
| REV | DESCRIPTION/EC NO. | DATE     |

UNLESS OTHERWISE SPECIFIED ALL DIMENSIONS IN INCHES

TOLERANCE UNLESS OTHERWISE NOTED:  
 .X = ±.05      ANGLES ±0.5°  
 .XX = ±.02  
 .XXX = ±.015

**Alcoa Fastening Systems**  
 AEROSPACE FASTENER DIVISION  
 3724 EAST COLUMBIA STREET  
 TUCSON, ARIZONA 85714  
 PHONE 520 519-7400  
 FAX 520 519-7427  
 www.alcoafasteners.com

|  |                                    |                 |  |
|--|------------------------------------|-----------------|--|
| TITLE<br><b>CAPTIVE SCREW, OPTIONAL RECESS, SPRING LOADED, ALL CRES, FULLY RETRACTABLE</b> |                                    |                 |  |
| DATE<br>11/29/2005   | PART NUMBER<br><b>FS( )( )7900</b> |                 |  |
| DRAWN<br>JLS   | DRAWING NO.<br><b>S-3396</b>       |                 |  |
| CHECK<br>  | CAGE CODE<br>0HDW7                 | REV<br><b>D</b> |  |
| APPROVE  | SCALE: 1:1                         | SHEET 2 OF 2    |  |