

HUCK® INTERACTIVE CD ROM : SPECIFICATIONS

256

256

Pneudraulic Installation Tool

Specifications

Weight:

5.03 kg (11.10 lbs.)

Required Air Pressure:

6.2-6.9 bar (90-100 psi)

Stroke:

22.4 mm (0.88")

Air Consumption:

22.5 CFM (637 l/min) based on
18-20 cycles per minute

Capacity:

44.42 kN @ 6.2 bar
(9986 lbs @ 90 psi)

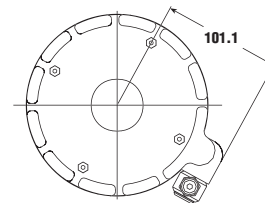
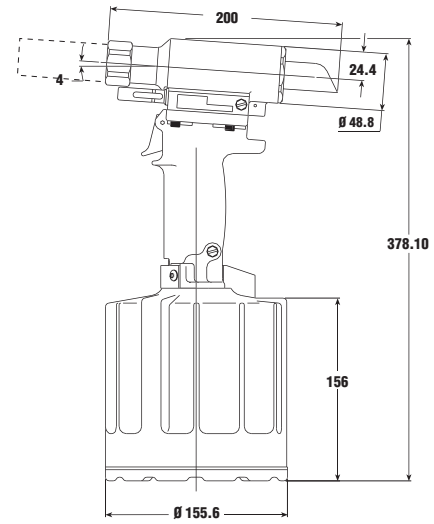
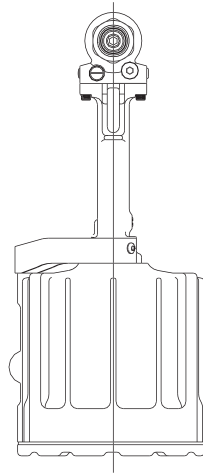

HUCK® INTERACTIVE CD ROM : NOSE ASSEMBLY TABLE

256

Some Fasteners & Nose Assemblies for use with the 256 Tool

Type	Diameter	Nose Assembly
BOM	4.8 mm (3/16")	99-1053
	6.4 mm (1/4")	99-830-1
MAGNA-LOK	9.5 mm (3/8")	99-3318
MAGNA-BULB	7.9 mm (5/16")	99-3307
C6L/C120L	4.8 mm (3/16")	99-2558, 99-2559
	6.4 mm (1/4")	99-2564, 99-2565
	7.9 mm (5/16")	99-99-245
	9.5 mm (3/8")	99-100-245 , 99-100-1D2
MAGNA-GRIP	4.8 mm (3/16")	99-3206
	6.4 mm (1/4")	99-3207
	7.9 mm (5/16")	99-1439
	9.5 mm (3/8")	99-1440
HUCKTAINER	9.5 mm (3/8")	99-3438

Items in **bold** are part of our FOCUS Tooling Range