

Alcoa
Fastening
Systems



INSTRUCTION MANUAL

244BT

PNEUDRAULIC INSTALLATION TOOL



Makers of Huck®, Marson®, Recoil®
Brand Fasteners, Tools & Accessories

10-09-2009
HK1113



EC Declaration of Conformity

Manufacturer:

Alcoa Fastening Systems, Industrial Products Group, 1 Corporate Drive, Kingston, NY, 12401, USA

Description of Machinery:

Model number 244BT

Relevant provisions complied with:

Council Directive related to Machinery (98/37/EC)
 British Standard related to hand held, non-electric power tools (EN 792-1)

European Representative:

Rob Pattenden, Huck International, Ltd. Unit C Stafford Park 7, Telford Shropshire TF3 3BQ, England, United Kingdom

Authorized Signature/date:

I, the undersigned, do hereby declare that the equipment specified above conforms to the above Directive(s) and Standard(s).

Signature:  _____

Full Name: Larry M. Krieg

Position: Engineering Manager
 Installation Systems Division

Place: Kingston, New York, USA

Date: September, 2009

Declared dual number noise emission values in accordance with ISO 4871	
A weighted sound power level, LWA: 80 dB (reference 1 pW) Uncertainty, KWA: 3 dB	
A weighted emission sound pressure level at the work station, LpA: 79 dB (reference 20 µPa) Uncertainty, KpA: 3 dB	
C-weighted peak emission sound pressure level, LpC, peak: 102 dB (reference 20 µPa) Uncertainty, KpC: 3 dB	
<i>Values determined according to noise test code ISO 15744, using as basic standards ISO 3744 and ISO 11203. The sum of a measured noise emission value and its associated uncertainty represents an upper boundary of the range of values which is likely to occur in measurements.</i>	
Declared vibration emission values in accordance with EN 12096	
Measured Vibrations emission value, a:	.016 m/s ²
Uncertainty, K:	.026 m/s ²
<i>Values measured and determined according to ISO 8662-1, ISO 5349-2, and EN 1033</i>	

Test data to support the above information is on file at Alcoa Fastening Systems, Industrial Products Group, Kingston Operations, Kingston, NY, USA.

CONTENTS

SAFETY4

SPECIFICATIONS5

PRINCIPLE OF OPERATION6

OPERATING INSTRUCTIONS7

PREPARATION FOR USE8

MAINTENANCE9

DISASSEMBLY10-11

ASSEMBLY12-13

FILL AND BLEED14-15

ASSEMBLY DRAWING 244BT16

PARTS LIST17

MEASURING TOOL STROKE18





TROUBLESHOOTING19

ACCESSORIES19

SAFETY

This instruction manual must be read, with particular attention to the following safety guidelines, by any person servicing or operating this tool.

1. Glossary

-  — Product complies with requirements set forth by the relevant European directives.
-  — Read manual prior to using equipment.
-  — Eye protection required while using this equipment.
-  — Hearing protection required while using this equipment.

 **WARNINGS - Must be understood to avoid severe personal injury.**

 **CAUTIONS - show conditions that will damage equipment and or structure.**

Notes - are reminders of required procedures.

Bold, Italic type and underlining - emphasizes a specific instruction.

2. A half hour long hands-on training session with qualified personnel is recommended before using Huck equipment.
3. Huck equipment must be maintained in a safe working condition at all times. Tools and hoses should be inspected on a regular basis for damage or wear. Any repair should be done by a qualified repairman trained on Huck procedures.
4. Repairman and Operator must read manual prior to using equipment. Warning and Caution stickers/labels supplied with equipment must be understood before connecting equipment to any primary power supply. As applicable, each of the sections in this manual have specific safety and other information.
5. Read MSDS Specifications before servicing the tool. MSDS Specifications are available from the product manufacturer or your Huck representative.
6. When repairing or operating Huck installation equipment, always wear approved eye protection. Where applicable, refer to ANSI Z87.1 - 2003
7. Disconnect primary power source before doing maintenance on Huck equipment or changing Nose Assembly.
8. Tools and hoses should be inspected for leaks at the beginning of each shift/day. If any equipment shows signs of damage, wear, or leakage, do not connect it to the primary power supply.
9. Mounting hardware should be checked at the beginning of each shift/day.
10. Make sure proper power source is used at all times.
11. Release tool trigger if power supply is interrupted.
12. Tools are not to be used in an explosive environment unless specifically designed to do so.
13. Never remove any safety guards or pintail deflectors.
14. Ensure deflector or pintail collector is installed and operating prior to use.
15. Never install a fastener in free air. Personal injury from fastener ejecting may occur.
16. Always clear spent pintail out of nose assembly before installing the next fastener.
17. There is possibility of forcible ejection of pintails or spent mandrels from front of tool.
18. If there is a pinch point between trigger and work piece, use remote trigger. (Remote triggers are available for all tooling).
19. Unsuitable postures may not allow counteracting of normal expected movement of tool.
20. Do not abuse tool by dropping or using it as a hammer. Never use hydraulic or air lines as a handle or to bend or pry the tool. Reasonable care of installation tools by operators is an important factor in maintaining tool efficiency, eliminating downtime, and in preventing an accident which may cause severe personal injury.
21. Never place hands between nose assembly and work piece. Keep hands clear from front of tool.
22. There is a risk of crushing if tool is cycled without Nose Assembly installed.
23. Tools with ejector rods should never be cycled with out nose assembly installed.
24. When two piece lock bolts are being used always make sure the collar orientation is correct. See fastener data sheet of correct positioning.
25. Tool is only to be used as stated in this manual. Any other use is prohibited.

TOOL SPECIFICATIONS

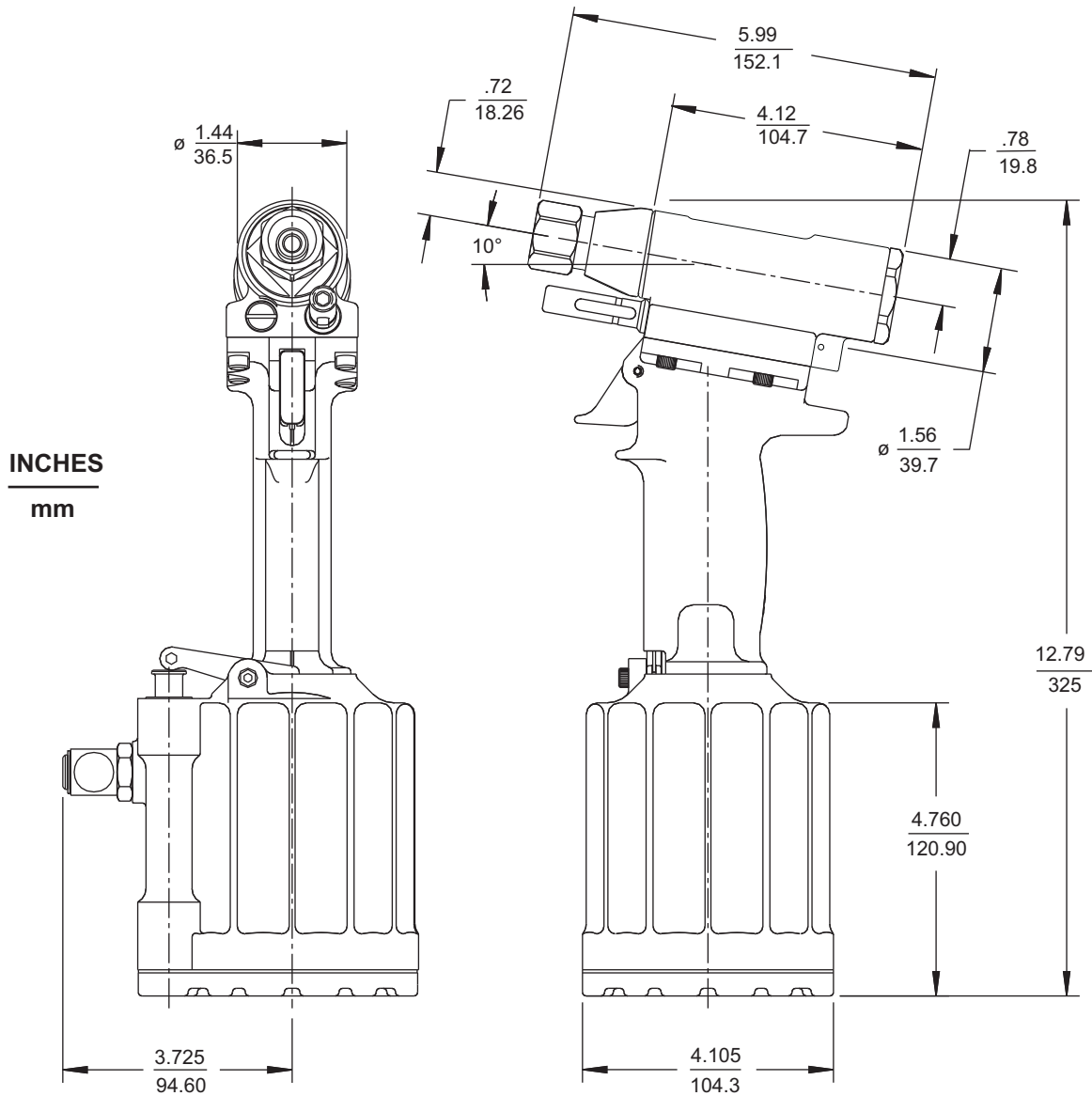

- **Stroke:** 1.032 in (2.621 cm)
- **Weight:** 6 lbs 5oz (2.86 kg)
- **Max Air Pressure:** 90 psi (6.2 BAR)
- **Max Flow Rate:** 6.3 scfm
- **Capacity:** 2365 lbs (1195 kg) @ 90 psi (6.2 BAR)
- **Speed/Cycles:** 30 per minute
- **Max Operating Temp:** 125°F (52°C)

PRINCIPLE OF OPERATION

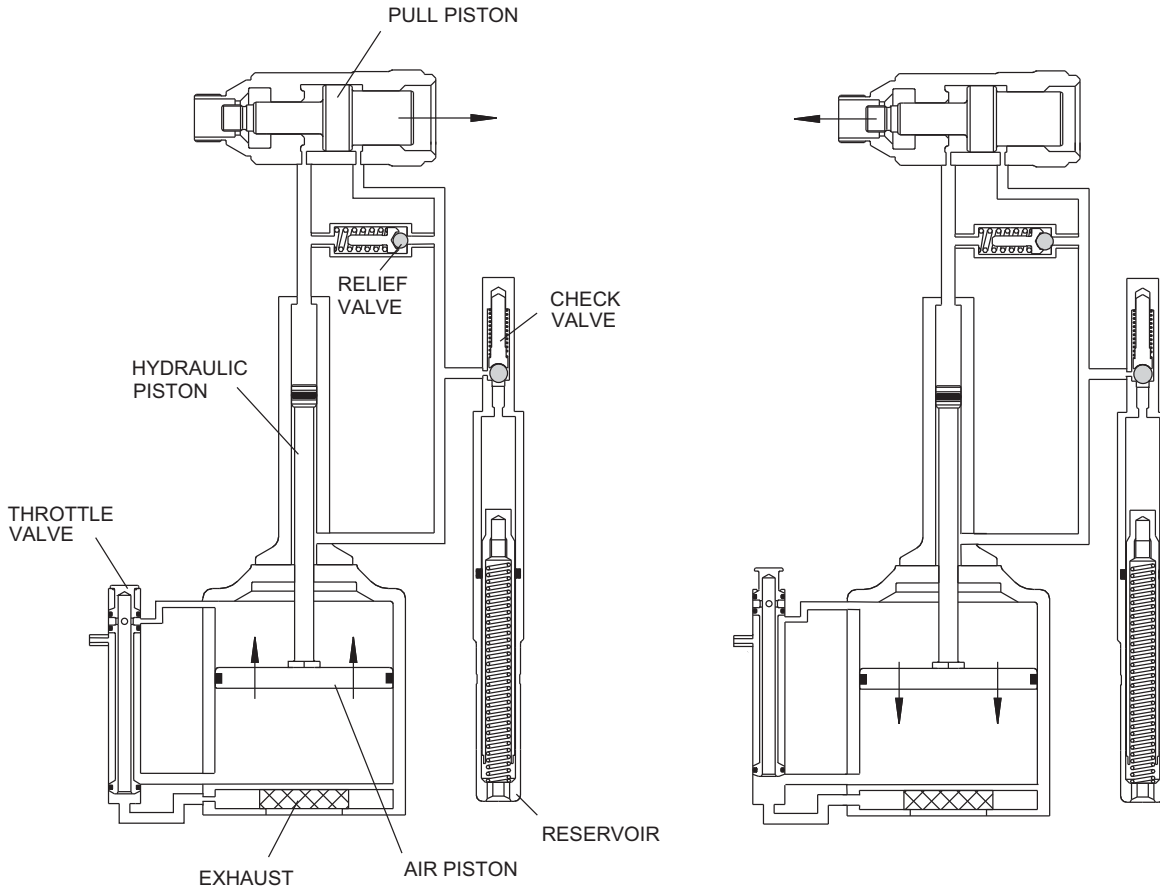

When the trigger is depressed the throttle valve moves to down position, pressurized air is directed to the bottom of the air piston, causing the piston to move upward. The air above the piston is exhausted and directed through the center of the throttle valve and out the bottom of the tool . The air piston has a rod and a hydraulic piston attached. When the air piston rod moves upward, a column of pressurized fluid is forced into head, which moves the pull piston back. The attached nose assembly moves with the pull piston spindle to start fastener installation.

When fastener installation is completed, the trigger is released. Air pressure with the assistance of a spring causes the throttle valve to return to its up position. Pressurized air is re-directed to the top of the air piston, causing the piston to move downward. The air from below the piston is exhausted through bottom of tool. The rod and hydraulic piston move downward; hydraulic pressure is reversed and the pull piston is returned forward. Return pressure relief valve protects tool against pressure spikes. The reservoir replenishes hydraulic system as needed.



OPERATING INSTRUCTIONS

For safe operation. Please read completely



WARNINGS:

- To avoid severe personal injury: **Wear approved eye and ear protection.**
- Be sure of adequate clearance for Operator's hands before proceeding with fastener installation.

GENERAL

Operators should receive training from qualified personnel.

Do not bend tool to free if stuck.

Tool should only be used to install fasteners. NEVER use as a jack/spreader or hammer.

BOBTAIL® Fastener Installation:



WARNING: Do not pull on a pin without placing fastener/collar in a workpiece, and also, collar chamfer **MUST** be out toward tool. These conditions cause pin to eject with great velocity and force when the pintail breaks off or teeth/grooves strip. This may cause severe personal injury.



CAUTIONS: Remove excess gap from between the sheets. This permits enough pintail to emerge from collar for ALL jaw teeth to engage with pintail. If ALL teeth do not engage properly, jaws will be damaged.

Place pin in workpiece and place collar over pin. See **WARNING**. (If Collar has only one tapered end, that end **MUST** be out toward tool; not next to sheet.) Hold pin and push nose assembly onto pin protruding through collar until nose anvil touches collar. Depress trigger and hold until collar is swaged and pintail breaks. Release trigger. Tool will go into its return stroke. Tool/nose are ready for next installation cycle.

- Place collar over pin. See WARNINGS. If collar has only one tapered end, that end should be outward toward tool.
- Hold pin in hole. Push tool onto pin protruding from collar until anvil touches collar.
- Move hands away from pin and structure. Keep hands away from front of tool during operation. Tool anvil advances forward.
- Hold tool at right angle (90 degrees) to work. Press and hold trigger down until collar is swaged.
- Release trigger. Tool returns to starting position.
- Tool is ready for next installation cycle.
- Length of tool increases during fastener installation. Allow adequate tool and anvil clearance before installing fasteners.
- Check pin for correct grip. Place pin in work hole.



PREPARATION FOR USE



WARNINGS:

Read full manual before using tool.

A half-hour training session with qualified personnel is recommended before using Huck equipment.

When operating Huck installation equipment, always wear approved eye protection.

Be sure there is adequate clearance for the operator's hands before proceeding.



CAUTION: Do not let disconnected hoses and couplers contact a dirty floor. Keep harmful material out of hydraulic fluid. Dirt in hydraulic fluid causes valve failure In Tool and In POWERIG Hydraulic Unit.



CAUTION: Do not use TEFLON®* tape on pipe threads. Pipe threads may cause tape to shred resulting in tool malfunction. (Slic-Tite* is available in stick form as Huck P/N 503237.)

The Model 244BT Installation Tool is shipped with a plastic plug in the air inlet connector. The connector has 1/4-18 female pipe threads to accept the air hose fitting. Quick disconnect fittings and 1/4" inside diameter air hose (1) are recommended. An air supply of 90-100 psi capable of 6.3 CFM must be available. Air supply should be equipped with a filter-regulator-lubricator unit.

1. Remove plastic shipping plug from Air Inlet Connector and put in a few drops of Automatic Transmission Fluid, DEXRON III, or equivalent.
2. Screw quick disconnect fitting into Air Inlet Connector.
3. Set air pressure on regulator to 90-100 psi.
4. Attach optional Air Hose (Huck part number 115436), supplied with tool, to air inlet connector.
5. Connect air hose to tool.
6. Cycle tool a few times by depressing and releasing trigger.

7. Disconnect air hose from tool.
8. Remove Retaining Nut and Stop.
9. Select proper Nose Assembly for fastener to be installed.
10. Attach Nose Assembly per Nose Assembly Data Sheet.
11. Connect air hose to tool and install fastener(s) in test plate of proper thickness with proper size holes. Inspect fastener(s).

NOTES:

- 1 Air quick disconnect fittings and air hoses are not available from Huck International, Inc.
- 2 On old style nose assemblies with lock collars, **VIBRA-TITE** should be used on collet threads, since there is no staking hole provided on the 244 pull piston. Refer to nose assembly data sheets.

* Slic-Tite is a registered trademark of LA-CO Industries, Inc.

* TEFLON is a registered trademark of DuPont Corp.



MAINTENANCE



CAUTIONS:

- Consult MSDS before servicing tool.
- Keep dirt and other material out of hydraulic system.
- Separated parts must be kept away from dirty work surfaces.
- Dirt/debris in hydraulic fluid causes Dump Valve failure in Tool and in POWERIG® Hydraulic Unit's valves.



CAUTION: Always replace seals, wipers, and back-up rings when tool is disassembled for any reason.



CAUTION: Do not use TEFLON®* tape on pipe threads. Pipe threads may cause tape to shred resulting in tool malfunction. (Slic-Tite is available in stick form as Huck P/N 503237.)

Note:

See **SPECIFICATIONS** for fluid type. Dispose of fluid in accordance with local environmental regulations. Recycle steel, aluminum, and plastic parts in accordance with local lawful and safe practices.

GENERAL

1. The efficiency and life of any tool depends upon proper maintenance. Regular inspection and correction of minor problems will keep tool operating efficiently and prevent downtime. The tool should be serviced by personnel who are thoroughly familiar with how it operates.
2. A clean, well lit area should be available for servicing the tool. Special care must be taken to prevent contamination of pneumatic and hydraulic systems.
3. Proper hand tools, both standard and special, must be available.
4. All parts must be handled carefully and examined for damage or wear. Always replace Seals, when tool is disassembled for any reason. Components should be disassembled and assembled in a straight line without bending, cocking, or undue force. Disassembly and assembly procedures outlined in this manual should be followed.
5. **Service Parts Kit 244BTKIT** includes consumable parts and should be available at all times. Other components, as experience dictates, should also be available.

DAILY

1. If a Filter-Regulator-Lubricator unit is not being used, uncouple air disconnects and put a few drops of Automatic Transmission Fluid or light oil into the air inlet of the tool. If the tool is in continuous use, put a few drops of oil in every two to three hours.
2. Bleed the air line to clear it of accumulated dirt or water before connecting air hose to the tool.
3. Check all hoses and couplings for damage or air leaks, tighten or replace if necessary.
4. Check the tool for damage or air/hydraulic leaks, tighten or replace if necessary.
5. Check the nose assembly for tightness or damage, tighten or replace if necessary.
6. Check oil level in tool reservoir, replenish if necessary.

WEEKLY

1. Disassemble and clean nose assemblies and reassemble per applicable Nose Assembly Data Sheet.
2. Check the tool and all connecting parts for damage or oil/air leaks, tighten or replace if necessary.



WARNING

Inspect tool for damage or wear before each use. Do not operate if damaged or worn, as severe personal injury may occur.



DISASSEMBLY

WARNING
 Be sure air hose is disconnected from tool before cleaning, or performing maintenance. Severe personal injury may occur if air hose is not disconnected.

(Refer to Figures 1-3 and 9)

NOTE: The following procedure is for complete disassembly of tool. Disassemble only those components necessary to replace damaged O-rings, Quad-Rings, Back-up Rings, and worn or damaged components. Always use soft jaw vice to avoid damage to tool.

1. Disconnect air hose from tool.
2. Remove nose assembly. Follow instructions on Nose Assembly Data sheet.
3. Insert Fill Tool, P/N 112465 through reservoir housing and screw into Reservoir Plunger (73) locking it in the out position (Fig1).
4. Unscrew Cap Screws (69) with 5/32 hex key. Carefully lift Head straight up from Handle (1), remove Pull Gland Assembly (29) and Return Gland Assembly (25) from separated head and handle assemblies (Fig1).
5. Unscrew Plug (85) of return Pressure Relief Valve from front of head. Remove Spring (84), valve Guide (82), Sleeve (83) and Steel Ball (81). A small magnet is helpful (Fig1).
6. Unscrew Bleed Plug (40). Hold over waste oil container and release fill tool slowly (Fig1).
7. Unscrew Housing/Spacer Assembly (70) from head. Remove two Springs (71). Slide Reservoir Plunger (73) from head. Remove spacer and Quad-Ring (72), a pick may be used to remove the Quad-Ring (Fig1).
8. Unscrew Plug (78) of reservoir check valve from side of head. Remove Spring (77), Check Valve Guide (76) and Stainless Steel Ball (75) (Fig1).

9. Unscrew End Cap (21) from Head, Plug & Seat Assembly (15) with 1 7/16 open end wrench.
10. (Fig. 2) Thread Piston Assembly Tool onto piston. Tap or press piston assembly out of head. Remove Nose Adapter (9). **NOTE: Piston will push out front and rear gland assembly.**
11. Remove Nose Adapter from front of Head, Plug & Seat Assembly (15). (Figs. 1 & 9).
12. If Seat (74) is damaged, contact your Huck representative. If Seat Assembly (80) is damaged, it can be removed by using Seat Removal Tool (126136) optionally available. **NOTE: Seats should not be reused. They should be replaced.**

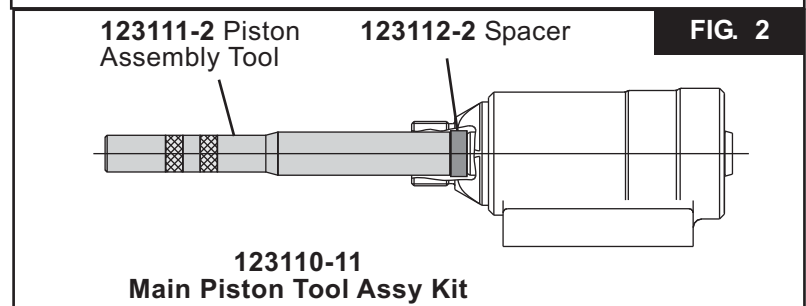
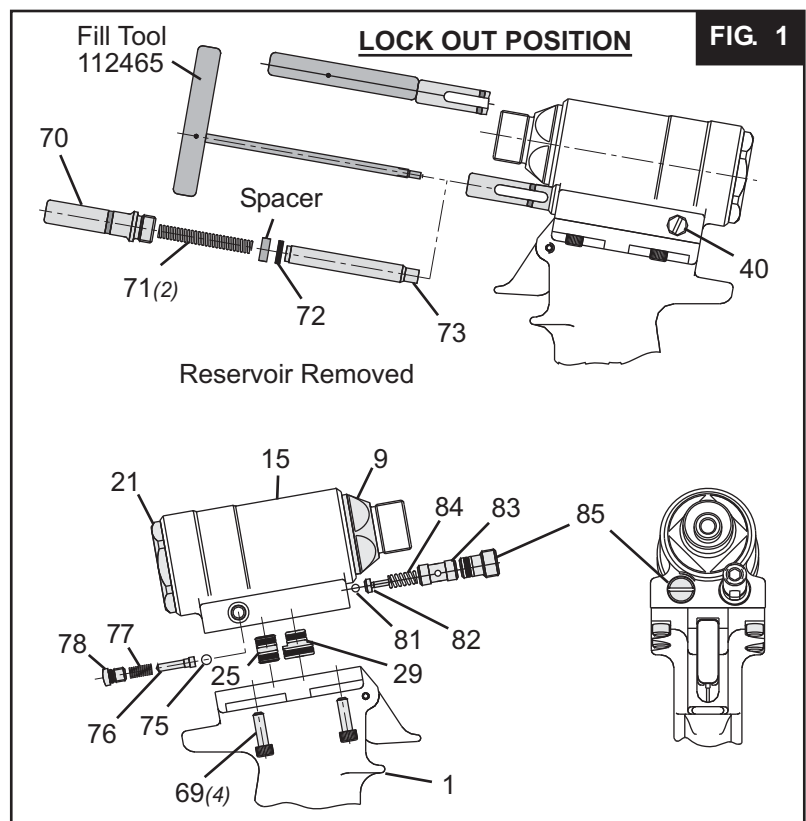



DISASSEMBLY (continued)

13. With a small punch and hammer, drive Roll Pin (4) that retains the Trigger (5) from the Handle (1). Remove Trigger Pin (3). Remove ball cable end from Throttle Arm (68) and pull Cable Assembly (2) out of Handle (1). (Fig. 3)
14. Remove Pivot Screw (64) and Lever Guard (94) from Throttle Arm (68). Remove Throttle Arm. Pull Throttle Valve (67) out of cylinder. Remove Spring (65) (Fig. 3).
15. Remove Bleed Plug (40) from handle (Fig. 3).
16. Hold tool inverted in vice. Unscrew three Button Head Screws (55) with 1/8 hex key (Fig3).
17. Remove Bottom Plate (56), Gasket (54) and Muffler (57) (Fig3).
18. Remove Retaining Ring (62) from Cylinder Assembly (51) (Fig3).
19. Install Screws (55) into Cylinder Head (60). Carefully pry under screws to remove cylinder head.
20. Push air piston all the way down in cylinder, lay tool on its side. Hold Locknut (58) with a 9/16 socket and extension and with 7/64 hex key, remove piston Screw (34).
21. Grip Locknut (58) under Air Piston with pliers and pull piston and rod assembly from handle and cylinder assembly.
22. Turn cylinder and handle upside down and secure in a vise.
23. With a 1 3/8 socket and extension, remove Gland Assembly (41). Handle and cylinder will now separate (Fig3).
24. Push Piston Assembly (33) out of handle. Push out from top to bottom.
25. Remove Swivel Assembly (86) from cylinder. Swivel Assembly may be disassembled to replace seals (32 & 87) if necessary. (Fig. 9)
26. To remove Polyseal (43) from Gland Assembly (41), remove Retaining Ring (45) and Spacer (44). (Fig. 9)



CAUTION: Care must be taken not to scratch piston rod or cylinder during removal.



CAUTION: A plastic or wooden drift must be used to avoid damaging the handle bore.

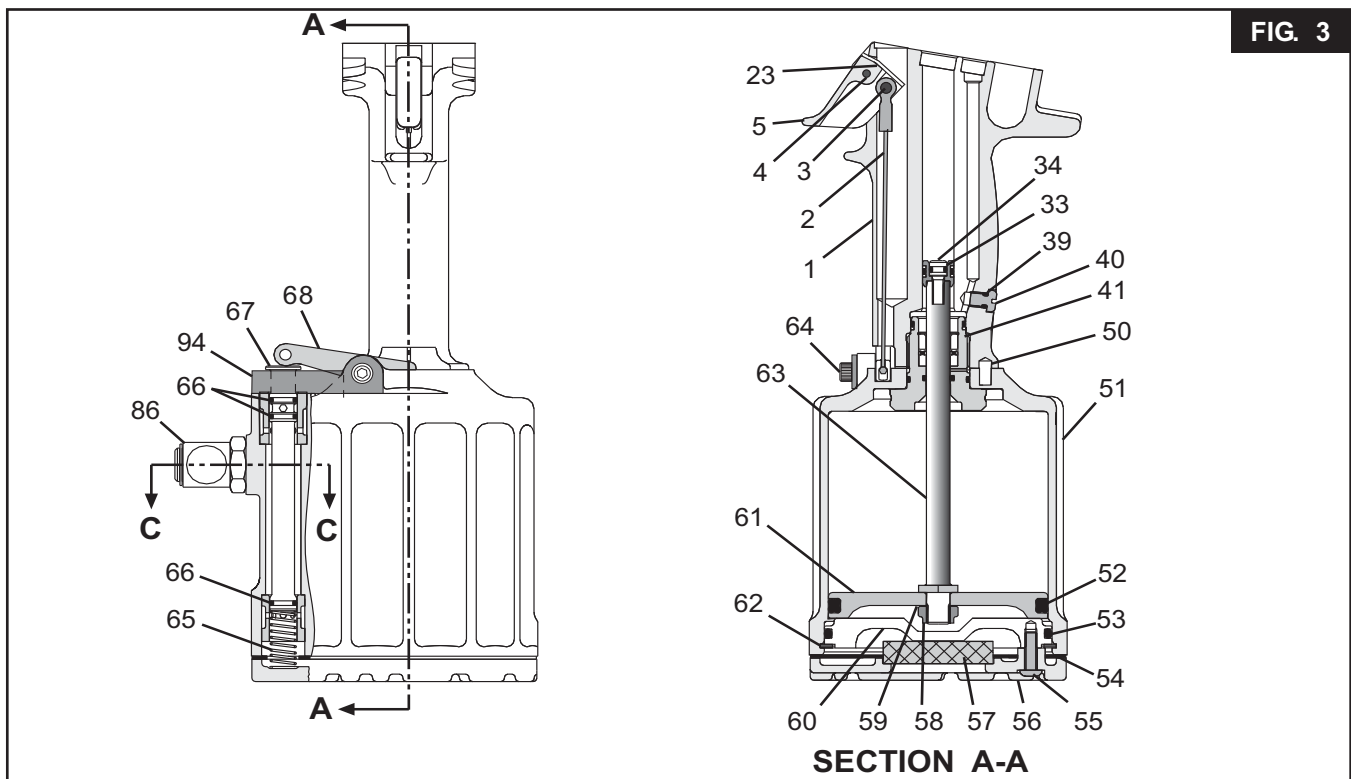



ASSEMBLY

WARNING: Do not omit any seals during servicing, leaks will result and personal injury may occur.

WARNING: Tool must be fully assembled with all components included.

(See Figures 4 thru 7 and 9.)

Clean components with mineral spirits or similar solvent; inspect for wear/damage and replace as necessary. Replace all seals of disassembled components. Use O-rings, Quad-Rings and Back-up rings in **Service Parts Kit 244BTKIT**. Smear LUBRIPLATE 130AA or PARKER-O-LUBE on O-rings, Quad-Rings, Back-up rings and mating parts to ease assembly, taking care not to damage O-rings, Quad-Rings, or Back-up rings.

1. Holding handle inverted in a vice, install Piston Assembly (33) (with O-ring (35) and Back-up rings (36) in place) in handle. (Fig. 4)

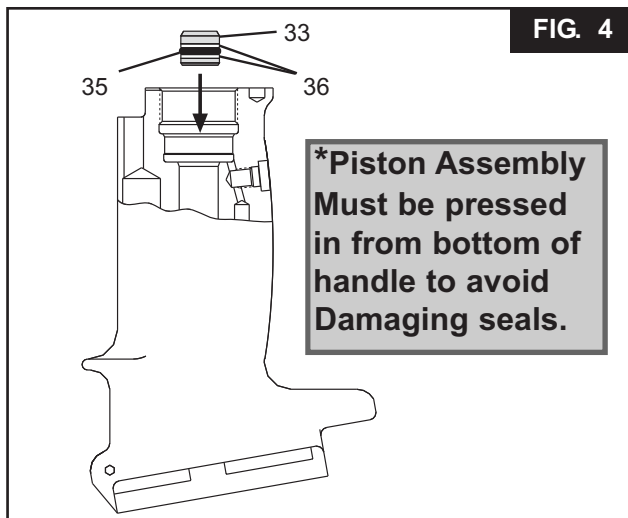

2. Place Cylinder Assembly (51) on handle with Timing Pin (50) positioned in matching hole. Assemble Gland Assembly (41) (See Fig. 9). Screw complete Gland assembly into handle. Torque to 75-80 ft. lbs. using a 1 3/8 socket wrench. (Fig 5)

3. Push Piston Rod (63) through Air Piston (61) from flat side. Drop Washer (59) over thread and screw Locknut (58) onto rod. Hold hex of rod with 9/16 wrench, and torque nut using 9/16 socket to 28-32 ft. lbs. (Fig 5).

CAUTION: Do NOT scratch piston rod.

4. Push assembled Air Piston and Rod into Air Cylinder and Gland Assembly (41) until it stops. Push Screw

(34) with o-ring in place through hydraulic Piston Assembly (33) and screw into top of piston rod. Hold Locknut (58) with 9/16 socket and extension and torque Screw (34) using 7/64 hex key to 55-60 in. lbs.

5. Push Cylinder Head (60) with O-ring (53) in place squarely into Cylinder. Install Retaining Ring (62). (Fig. 6)
6. Hold handle upside down in vise. Position Muffler (57) on center of Cylinder Head (60), Place Gasket (54) on Cylinder Assembly (51), place Bottom Plate (56) on top of Gasket and secure with 3 Button Head Screws (55) using 1/8 hex key. (Fig. 6)
7. Turn tool upright. Drop Spring (65) into Throttle Valve hole in Cylinder. Push Throttle Valve (67) with O-rings (66) in place into Cylinder. (Fig. 6)
8. Assemble Trigger (5), Cable Assembly (2) and Trigger Pin (3) together and slide cable into Handle (1). Align hole in Trigger and hole in handle ears and install Roll Pin (4) with a hammer and punch. (Fig. 6)

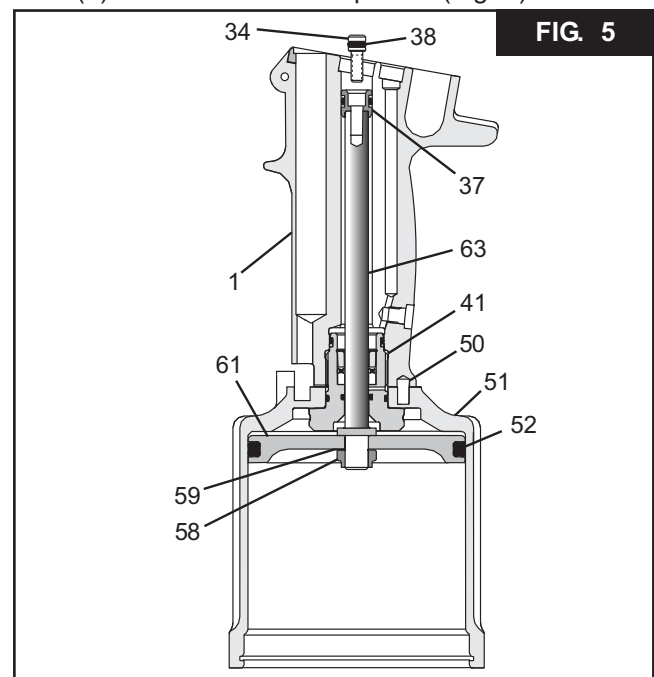

9. Slide Throttle Arm (68) onto ball end of Throttle Cable. Swing arm until other end fits over throttle valve. Place Lever Guard (94) over Throttle Arm and install Pivot Screw (64) through Throttle Arm. Tighten with 5/32 hex key.

10. Install Swivel Assembly (86) in Cylinder Assembly (51). (Fig. 9)

11. If Air Hose 115436 was removed, reinstall in swivel assembly.



ASSEMBLY (continued)

12. If Seat Assembly (80) is being replaced, push seat and seal assembly in using soft drift. Take care not to damage ball seat surface. (Fig. 9)
13. Assemble hydraulic Piston (18) with new seals (16,17). Lubricate with LUBRIPLATE or PARKER SUPER-O-LUBE. (Fig. 9)
14. Install Nose Adapter (9) on front of head. (Use VIBRA-TITE Huck P/N 505125 on threads). Torque to 50-60 ft. lbs. (Fig. 7)
15. Assemble Front Gland (12) Gland Cap (11) O-ring (14) Back-up Ring (13) and Polyseal (6). Thread Piston Assembly Tool 123111-2 onto Piston (18). Slide complete Front Gland Assembly and Wiper Seal (10) over Piston Assembly Tool onto Piston. (Fig. 7)
16. Press entire piston and gland assembly into head. Remove Piston Assembly Tool from piston. (Fig. 7)
17. (Fig. 9)
Place Seals (20) and (24) on Rear Gland (19). Push complete assembly into head and screw in End Cap (21), and torque to 50 - 60 ft. lbs.

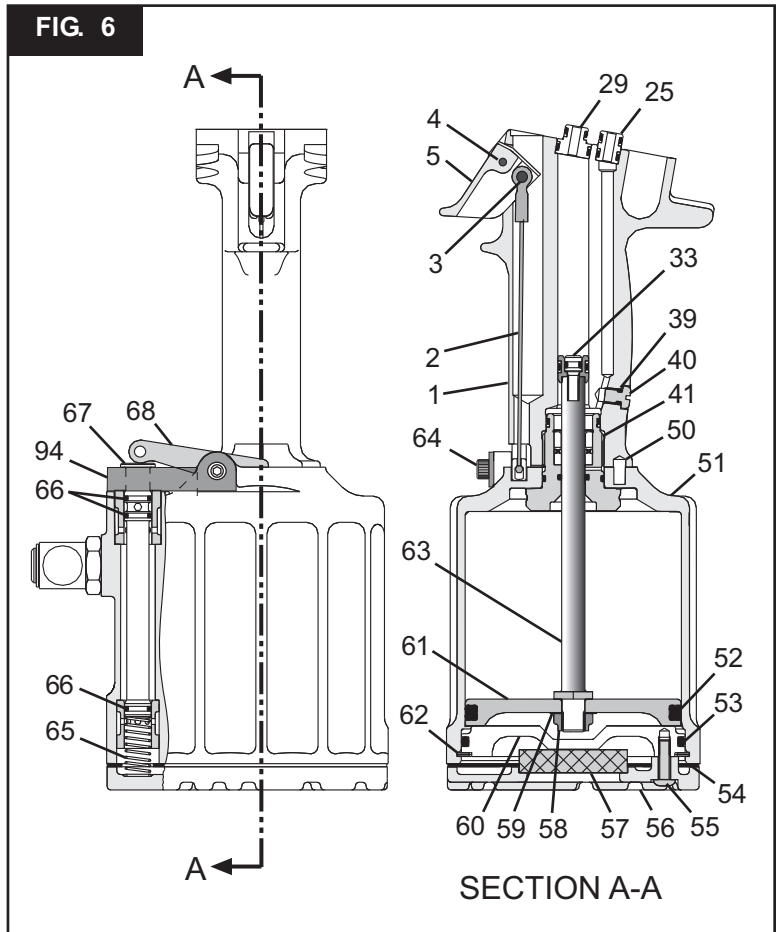

18. Install Quad-Ring (72) and Spacer. Slide Reservoir Plunger (73) in. Install two Springs (71). Screw Housing/Spacer Assembly into head. (Fig. 1)
19. (Fig. 1 & 9)
Push Pintail Deflector (22) onto rear of Piston (18).
20. Place O-ring (39) on Plug (40) and screw assembly into Handle (1). (Fig. 6)
21. Install Pull (29) and Return (25) Gland Assemblies in handle. Push head down on glands. Place tool in a vise Head down and install 4 Screws (69) and torque to 170 inch pounds. (Fig. 6 & 9)

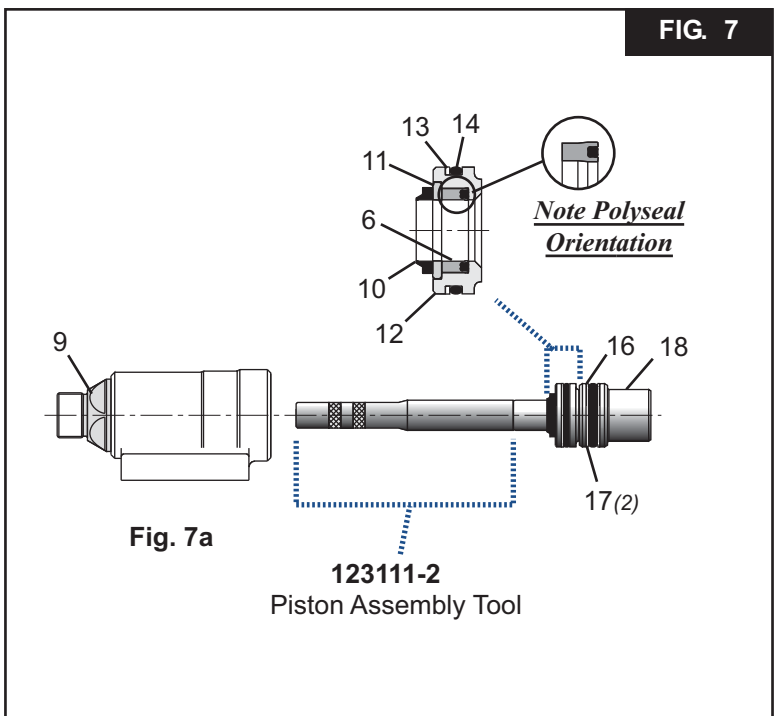

22. Tool is now completely assembled except for relief and check valves. See **FILL AND BLEED** procedure for replacement of valve components.



FILL AND BLEED

Equipment Required:

- Shop airline with 90-100 psi max.
- Air regulator
- Fill Bottle 120337 (supplied with tool).
- Fill Tool Assy 112465
- Large flat blade screwdriver
- Stall Nut 124090

Preparation:

1. Install air regulator in airline and set pressure to 20-40 psi.
2. Fill bleed bottle almost full of DEXRON III - ATF (automatic transmission fluid) (See Fig. 8.)

Refill tool only when red line on plunger drops below the red line on the reservoir housing or when tool is rebuilt. REFILL: AUTOMATIC TRANSMISSION FLUID DEXRON III, OR EQUIVALENT.

Step 1

Screw Fill Tool P/N 112465 into Reservoir Plunger, pull Plunger into Housing and lock Fill Tool in full forward position by tilting handle (long side touching tool) and locking in place.

Step 2

Remove Relief Valve and Check Valve plugs, guides, springs and balls from ports in head. Reinstall Plug (85) and sleeve (83) in head in Relief Valve port (front of tool).

Step 3

(Fig. 8)

Screw retaining nut onto Head Assembly. Screw Stall Nut onto Piston and tighten to ensure full thread engagement. Back off retaining nut until it engages stall nut. Check Piston location. *Piston must be all the way forward and locked with stall nut and retaining nut.*

Step 4

(Fig. 8)

Attach the tool air source momentarily to seat air piston at bottom of cylinder - disconnect tool. With fill port facing up, (check valve on side) lay tool on its side.

continued

FIG. 8

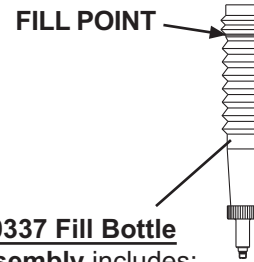
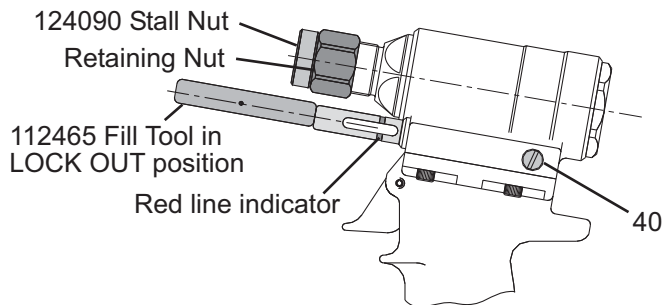

120337 Fill Bottle Assembly includes:
120336 Fill Bottle
120004 Cap

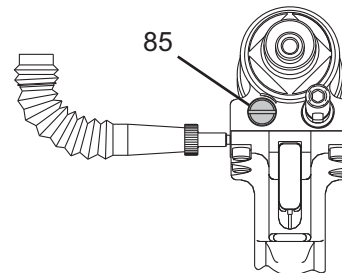
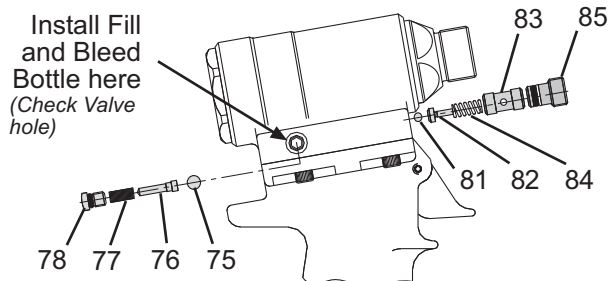



FILL AND BLEED (continued)

Step 5

(Fig. 8)

Install fill bottle in head fill port (check Valve hole).

Step 6

Connect tool to shop air 20 to 40 psi. Cycle tool 20-30 times, watch for air bubbles escaping from the tool into bottle. (You may rock the tool to free trapped air in the tool.) Do not allow the air to re-enter the tool. When cycling tool, always hold bottle up as shown in Figure 8 to prevent drawing in air from empty part of bottle.

WARNING
Air pressure **MUST** be set to 20 to 40 psi to prevent possible injury from high pressure spray. If plug (78) is removed, fill bottle must be in place before cycling tool.

Step 7

When air bubbles no longer appear in bottle, remove fill bottle while tool is lying on its side.

Step 8

Install the check valve Ball (75), Check Valve Guide (76) and Spring (77). Replace the Plug (78).

Step 9

Turn tool so front of head faces you and remove the relief valve Plug (85). Prior to removing Plug (85), it is advisable to back out setscrew inside of plug by approximately 1/2 turn counterclockwise. (See Figure 8a). This ensures that the Piston will remain in full-forward position. Install relief valve Ball (81), Guide (82), Sleeve (83) and Spring (84). Replace the Plug (85).

Step 10

(Fig. 8)

Unlock Fill Tool and check Reservoir red line. At this point cycle the tool the with Stall Nut attached and retaining nut locked in the full forward position ("Dead Stall"). Reservoir should not drop below the red line on the reservoir housing.

Step 11

Re-lock the fill tool. Lay tool on its left side and remove Plug (40). Top off reservoir by placing a few drops of oil in hole and waiting for air bubbles to escape. Push a pin or a scribe into hole to check for trapped air bubbles. Replace plug.

WARNING
Failure to re-lock the fill tool will result in oil being ejected from the head under pressure during the topping off of the reservoir. Severe personal injury may result.

Step 12

Unlock the fill tool and cycle tool as in step 10. Reservoir may drop slightly. If so, repeat step 11 until when you touch the fill tool handle, it has no pressure against it and it drops out of the lock position, and the plunger does not drop when tool is cycled. **NOTE: This usually requires 3 to 4 times topping off.**

Step 13

(Fig. 8)

Remove fill tool and stall nut. Install a nose assembly and pull several fasteners to test function.

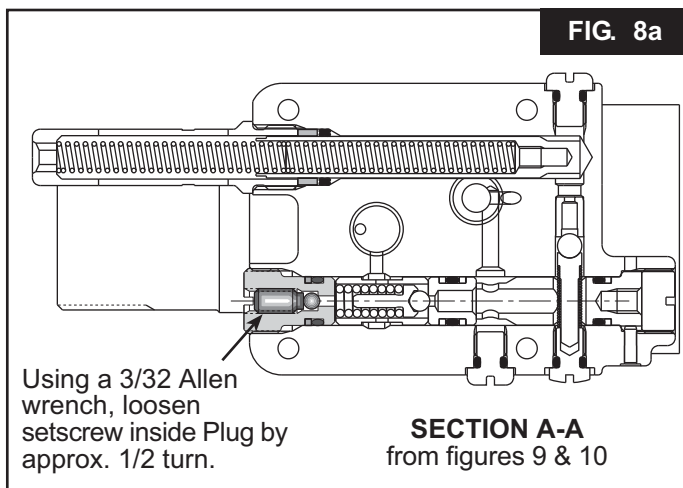

ASSEMBLY DRAWING

FIG. 9

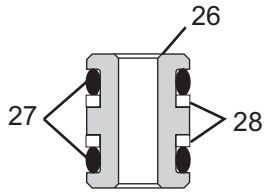

25 Return Gland Assembly

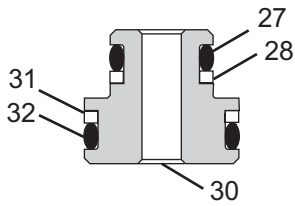

29 Pull Gland Assembly

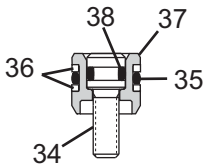

33 Piston Assembly

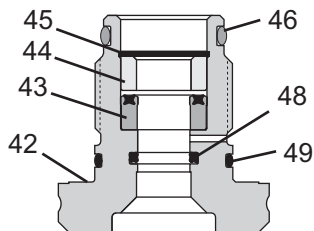

41 Gland Assembly

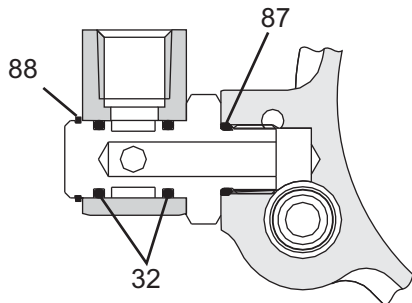

86 Swivel Assembly
SECTION C-C

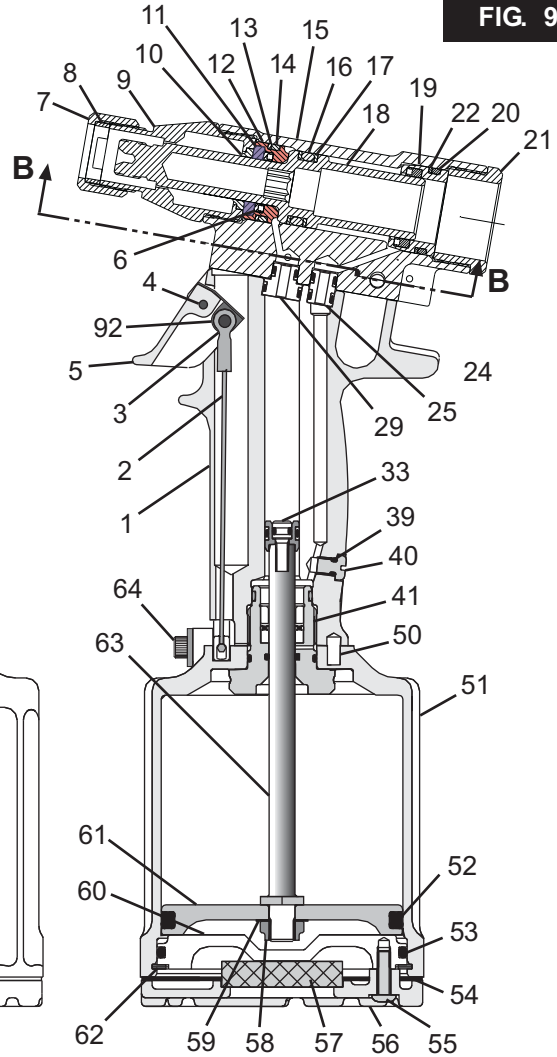
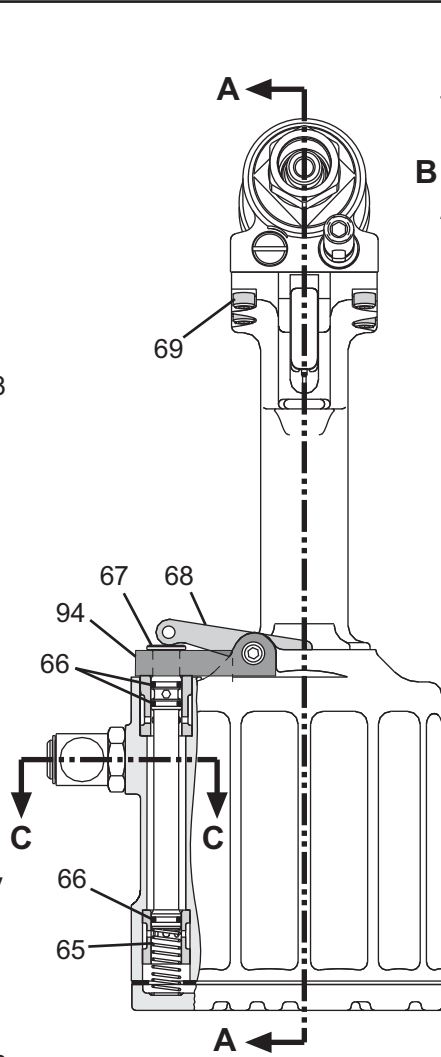

SECTION A-A

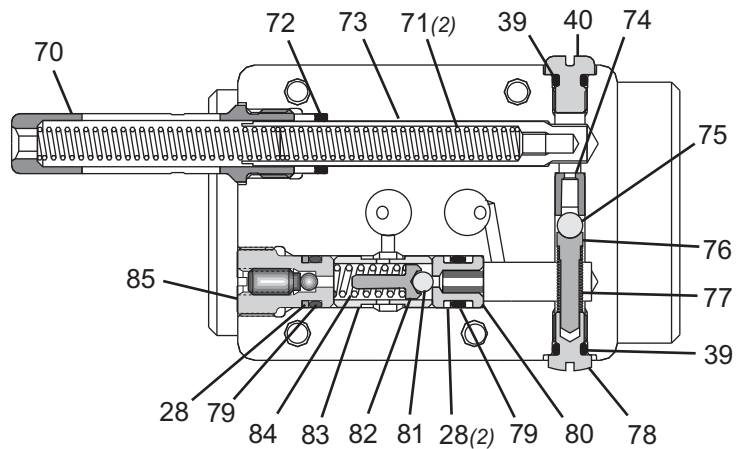

SECTION B-B

PARTS LIST *(Refer to Figure 9)*

Item	Description	244	Qty
1	Handle	125550	1
2	Cable Assy	116404-1	1
3	Trigger Cable Pin	505496	1
4	Roll Pin	500621	1
5	Trigger	124333-2	1
6	Polyseal	505827	1
7	Retaining Nut	111795	1
8	Stop	120588	1
9	Nose Adapter	129166	1
10	Wiper Seal	505817	1
11	Gland Cap	129167	1
12	Front Gland	129164	1
13	Back-up Ring	501110	1
14	O-Ring	500816	1
15	Head Plug Seat Assy	129168	1
16	O-Ring	500844	1
17	Back-up Ring	501138	2
18	Hydraulic Piston	129162	1
19	Rear Gland	129165	1
20	O-Ring	500818	1
21	End Cap	129163	1
22	Back-up Ring	501112	1
23	Screw	n/a	1
24	Polyseal	508398	1
25	Return Gland Assy	125555	1
26	Gland Housing	125554	1
27	O-Ring	500776	3
28	Back-up Ring	501082	6
29	Pull Gland Assy	125553	1
30	Pull Gland Housing	125552	1
31	Back-up Ring	501085	1
32	O-Ring	500779	3
33	Piston Assy	118865	1
34	Screw	117773	1
35	O-Ring	503768	1
36	Back-up Ring	501084	2
37	Piston	117774	1
38	O-Ring	500773	1
39	O-Ring	505438	3
40	Plug	100309	2
41	Gland Assy	125557	1
42	Gland	126311	1
43	Polyseal	506611	1
44	Spacer	123904	1
45	Retaining Ring	505939	1
46	O-Ring	500812	1
47	O-Ring	n/a	1
48	Quad Ring	501074	1
49	O-Ring	500786	1
50	Timing Pin	505496	1

Item	Description	244	Qty
51	Cylinder Assy	125560	1
52	Quad Ring	501456	1
53	O-Ring	500869	1
54	Gasket	126941-1	1
55	Screw	504127	3
56	Bottom Plate	128790	1
57	Muffler	115554-1	1
58	Locknut	505420	1
59	Washer	506493	1
60	Cylinder Head	111959-1	1
61	Air Piston	123753	1
62	Retaining Ring	506490	1
63	Piston Rod	125561	1
64	Pivot Screw	125118	1
65	Spring	116272	1
66	O-Ring	507396	3
67	Throttle Valve	125562	1
68	Throttle Arm	123754	1
69	Screw	500062	4
70	Housing Spacer Assy	112403	1
71	Spring	505864	2
72	Quad Ring	501408	1
73	Reservoir Plunger	112405	1
74	Seat	111139	1
75	Ball	502929	1
76	Check Valve Guide	111067	1
77	Spring	100874	1
78	Plug	111068	1
79	O-Ring	505446	2
80	Seat Assy	126134	1
81	Ball	502506	1
82	Guide	120128	1
83	Sleeve	120127	1
84	Spring	507403	1
85	Plug	114530	1
86	Swivel Assy	507164	1
87	O-Ring	500778	1
88	Retaining Ring	502274	1
89	Locknut	n/a	1
90	Stop	n/a	1
91	Spring	n/a	1
92	Trigger Stop	125766	1
93	Stall Nut (not shown)	124090	1
94	Lever Guard	125117	1

MEASURING TOOL STROKE

FIG. 11

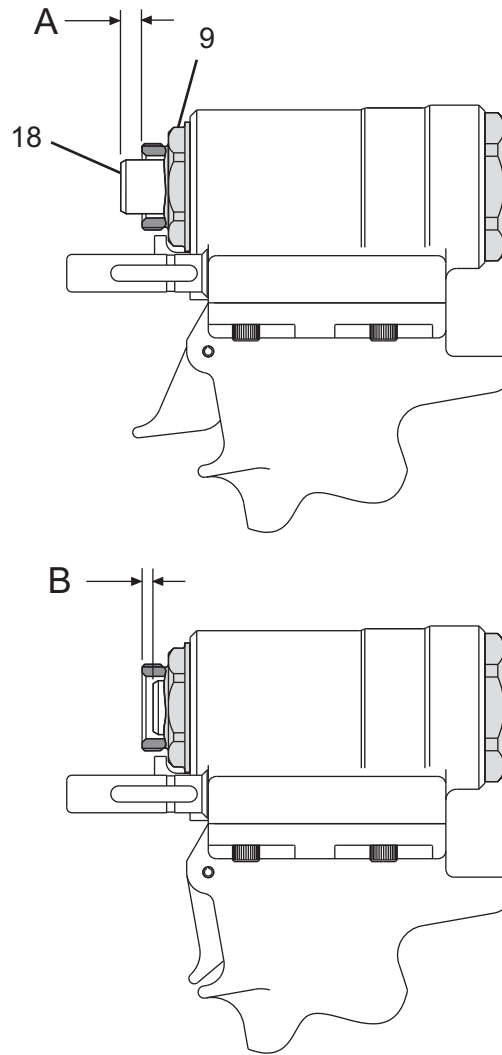

1. Measure distance "A" from face of Piston (18) to face of Nose Adapter (9). This distance should be approximately equal to .173 inches.
2. Cycle tool and hold piston back by keeping the trigger depressed. Measure distance "B" as above.
3. $STROKE = A+B$

TROUBLESHOOTING

Always check out the simplest possible cause of a malfunction first. For example, an air hose not connected. Then proceed logically, eliminating each possible cause until the cause is located. Where possible, substitute known good parts for suspected bad parts. Use TROUBLESHOOTING CHART as an aid in locating and correcting malfunction.

NOTE:

Piston Drift is when the air piston is in the down position, but the hydraulic pull piston is not in the full forward position. This causes an out of sequence condition.

- 1 Tool fails to operate when trigger is depressed.**
 - a) Air line not connected
 - b) Throttle Valve O-rings (66), worn or damaged.
 - c) Throttle valve Cable Assembly (2) is broken.
- 2 Tool does not complete fastener installation and break pintail.**
 - a) Air pressure too low
 - b) Air Piston Quad-Ring (52) worn or damaged.
 - c) Reservoir empty or low, refer to Fill and Bleed section.
 - d) Air in hydraulic system, refer to Fill and Bleed section.
 - e) Reservoir Springs (71) worn or damaged
 - f) Check for piston drift
- 3 Pintail stripped and/or swaged collar not ejected.**
 - a) Check for broken or worn jaws in nose assembly, refer to nose assembly data sheet.
 - b) Check for loose Retaining Nut (7)
 - c) Check for piston drift.
- 4 Tool has piston drift.**
 - a) Loose collet crashing into the front of the anvil, this causes the relief valve to open allowing the piston to drift. Tighten the collet and refer to Fill and Bleed section.
 - b) Worn or damaged Return Pressure Relief Valve in tool, inspect Seat Assembly (80), O-ring (27), Back-up Rings (28), Steel Ball (81) and Valve Spring (84). Replace if necessary.
 - c) Worn or damaged Piston Assembly (33); Inspect O-ring (35), O-ring (38) and Back-up Rings (36). Replace if necessary.
- 5 Hydraulic fluid exhausts with air or leaks at base of handle.**
 - a) Worn or damaged Gland Assembly (41); Inspect Polyseal (43), O-rings (46 & 49) and Quad-Ring (48). Replace if necessary.
- 6. Hydraulic fluid leaks at rear of Pull Piston (18)**
 - a) Worn or damaged Rear Gland (19), inspect Polyseal (24) and O-ring (20). Replace if necessary.
- 7. Hydraulic fluid leaks at front of Pull Piston (18).**
 - a) Worn or damaged Front Gland (12); Inspect Polyseal (6), O-ring (14) and Back-up Ring (13). Replace if necessary.
- 8. Pull Piston (18) will not return.**
 - a) Throttle Valve (67) stuck; Lubricate O-rings (66).
 - b) Throttle Arm (68), Cable Assembly (2) or Trigger (5) binding.
- 9. Air leaks at air Cylinder Head (60).**
 - a) Worn or damaged O-ring (53). Replace if necessary.

ACCESSORIES

Fill and Bleed Bottle (Fig.8)	-	120337
Seat Removal Tool	-	126136
Fill Tool Assy for reservoir (Fig.8)	-	112465
Stall Nut (Fig.8)	-	124090
Piston Assembly Tool Kit	-	123110-11
<i>Includes:</i>		
Piston Assembly Tool (Fig. 2)	-	123111-2
Spacer (Fig. 2)	-	123112-2
Service Tool Kit	-	120352-244
<i>Includes:</i>		
Fill and Bleed Bottle (Fig.8)	-	120337
Fill Tool for reservoir (Fig.8)	-	112465
Stall Nut (Fig.8)	-	124090

SERVICE NOTES

LIMITED WARRANTIES

Tooling Warranty: Huck warrants that tooling and other items (excluding fasteners, and hereinafter referred as "other items") manufactured by Huck shall be free from defects in workmanship and materials for a period of ninety (90) days from the date of original purchase.

Warranty on "non standard or custom manufactured products": With regard to non-standard products or custom manufactured products to customer's specifications, Huck warrants for a period of ninety (90) days from the date of purchase that such products shall meet Buyer's specifications, be free of defects in workmanship and materials. Such warranty shall not be effective with respect to non-standard or custom products manufactured using buyer-supplied molds, material, tooling and fixtures that are not in good condition or repair and suitable for their intended purpose.

THERE ARE NO WARRANTIES WHICH EXTEND BEYOND THE DESCRIPTION ON THE FACE HEREOF. HUCK MAKES NO OTHER WARRANTIES AND EXPRESSLY DISCLAIMS ANY OTHER WARRANTIES, INCLUDING IMPLIED WARRANTIES AS TO MERCHANTABILITY OR AS TO THE FITNESS OF THE TOOLING, OTHER ITEMS, NONSTANDARD OR CUSTOM MANUFACTURED PRODUCTS FOR ANY PARTICULAR PURPOSE AND HUCK SHALL NOT BE LIABLE FOR ANY LOSS OR DAMAGE, DIRECTLY OR INDIRECTLY, ARISING FROM THE USE OF SUCH TOOLING, OTHER ITEMS, NONSTANDARD OR CUSTOM MANUFACTURED PRODUCTS OR BREACH OF WARRANTY OR FOR ANY CLAIM FOR INCIDENTAL OR CONSEQUENTIAL DAMAGES.

Huck's sole liability and Buyer's exclusive remedy for any breach of warranty shall be limited, at Huck's option, to replacement or repair, at FOB Huck's plant, of Huck manufactured tooling, other items, nonstandard or custom products found to be defective in specifications, workmanship and materials not otherwise the direct or indirect cause of Buyer supplied molds, material, tooling or fixtures. Buyer shall give Huck written notice of claims for defects within the ninety (90) day warranty period for tooling, other items, nonstandard or custom products described above and Huck shall inspect products for which such claim is made.

Tooling, Part(s) and Other Items not manufactured by Huck.

HUCK MAKES NO WARRANTY WITH RESPECT TO THE TOOLING, PART(S) OR OTHER ITEMS MANUFACTURED BY THIRD PARTIES. HUCK EXPRESSLY DISCLAIMS ANY WARRANTY EXPRESSED OR IMPLIED, AS TO THE CONDITION,

DESIGN, OPERATION, MERCHANTABILITY OR FITNESS FOR USE OF ANY TOOL, PART(S), OR OTHER ITEMS THEREOF NOT MANUFACTURED BY HUCK. HUCK SHALL NOT BE LIABLE FOR ANY LOSS OR DAMAGE, DIRECTLY OR INDIRECTLY, ARISING FROM THE USE OF SUCH TOOLING, PART(S) OR OTHER ITEMS OR BREACH OF WARRANTY OR FOR ANY CLAIM FOR INCIDENTAL OR CONSEQUENTIAL DAMAGES.

The only warranties made with respect to such tool, part(s) or other items thereof are those made by the manufacturer thereof and Huck agrees to cooperate with Buyer in enforcing such warranties when such action is necessary.

Huck shall not be liable for any loss or damage resulting from delays or nonfulfillment of orders owing to strikes, fires, accidents, transportation companies or for any reason or reasons beyond the control of the Huck or its suppliers.

Huck Installation Equipment

Huck International, Inc. reserves the right to make changes in specifications and design and to discontinue models without notice.

Huck Installation Equipment should be serviced by trained service technicians only.

Always give the Serial Number of the equipment when corresponding or ordering service parts.

Complete repair facilities are maintained by Huck International, Inc. Please contact one of the offices listed below.

Eastern

One Corporate Drive Kingston, New York 12401-0250
Telephone (845) 331-7300 FAX (845) 334-7333

Canada

6150 Kennedy Road Unit 10, Mississauga, Ontario, L5T2J4, Canada.
Telephone (905) 564-4825 FAX (905) 564-1963

Outside USA and Canada

Contact your nearest Huck International Office, see back cover.

In addition to the above repair facilities, there are Authorized Tool Service Centers (ATSC's) located throughout the United States. These service centers offer repair services, spare parts, Service Parts Kits, Service Tools Kits and Nose Assemblies. Please contact your Huck Representative or the nearest Huck office listed on the back cover for the ATSC in your area.



For the Long Haul™

A Global Organization

Alcoa Fastening Systems (AFS) maintains company offices throughout the United States and Canada, with subsidiary offices in many other countries. Authorized AFS distributors are also located in many of the world's

industrial and Aerospace centers, where they provide a ready source of AFS fasteners, installation tools, tool parts, and application assistance.

Alcoa Fastening Systems world-wide locations:

Americas

Alcoa Fastening Systems

Aerospace Products

Tucson Operations

3724 East Columbia
Tucson, AZ 85714
800-234-4825
520-747-9898
FAX: 520-748-2142

Alcoa Fastening Systems

Aerospace Products

Carson Operations

PO Box 5268
900 Watson Center Rd.
Carson, CA 90749
800-421-1459
310-830-8200
FAX: 310-830-1436

Alcoa Fastening Systems

Commercial Products

Waco Operations

PO Box 8117
8001 Imperial Drive
Waco, TX 76714-8117
800-388-4825
254-776-2000
FAX: 254-751-5259

Alcoa Fastening Systems

Commercial Products

Kingston Operations

1 Corporate Drive
Kingston, NY 12401
800-431-3091
845-331-7300
FAX: 845-334-7333
www.hucktools.com

Alcoa Fastening Systems

Commercial Products

Canada Operations

6150 Kennedy Road, Unit 10
Mississauga, Ontario L5T2J4
Canada
905-564-4825
FAX: 905-564-1963

Alcoa Fastening Systems

Commercial Products

Latin America Operations

Avenida Parque Lira. 79-402
Tacubaya Mexico, D.F.
C.P. 11850
FAX: 525-515-1776
TELEX: 1173530 LUKSME

Far East

Alcoa Fastening Systems

Commercial Products

Australia Operations

14 Viewtech Place
Rowville, Victoria
Australia 3178
03-764-5500
Toll Free: 008-335-030
FAX: 03-764-5510

Europe

Alcoa Fastening Systems

Commercial Products

United Kingdom Operations

Unit C, Stafford Park 7
Telford, Shropshire
England TF3 3BQ
01952-290011
FAX: 0952-290459

Alcoa Fastening Systems

Aerospace Products

France Operations

Clos D'Asseville
BP4
95450 Us Par Vigny
France
33-1-30-27-9500
FAX: 33-1-34-66-0600



For The Long Haul, The Future of Fastening Technology, The Future of Assembly Technology, The Future of Tooling Technology, and Tools of Productivity are service marks of Huck International. Huck provides technical assistance regarding the use and application of Huck fasteners and tooling.

NOTICE: The information contained in this publication is only for general guidance with regard to properties of the products shown

and/or the means for selecting such products, and is not intended to create any warranty, express, implied, or statutory; all warranties are contained only in Huck's written quotations, acknowledgements, and/or purchase orders. It is recommended that the user secure specific, up-to-date data and information regarding each application and/or use of such products.

HWB898 1003-5M

Alcoa Fastening Systems



One Great ConnectionSM