

# HUCK® INTERACTIVE CD ROM : SPECIFICATIONS

## 202V

### 202V

#### Pneudraulic Installation Tool

##### Specifications

*Weight:*

2.31 kg (5.1 lbs)

*Required Air Pressure:*

5.5 -6.9 bar (80-100 psi)

*Air Consumption:*

8.6 CFM (244 l/min) based on  
30 cycles per minute

*Stroke:*

18.9 mm (0.743")

*Hydraulic Fluid:*

Automatic Transmission Fluid  
DEXTRON II® or equivalent

*Capacity:*

17.3 kN @ 6.21 bar  
(3889 lbs @ 90 psi)

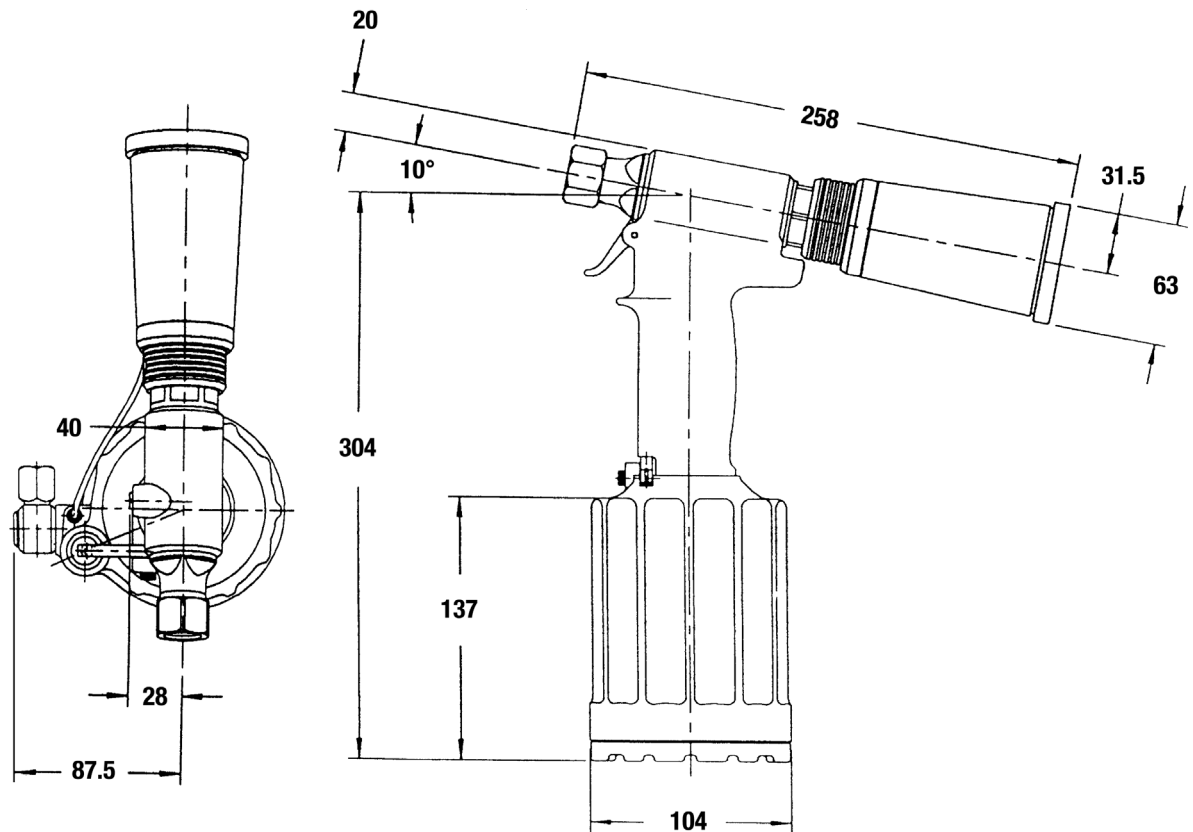

# HUCK® INTERACTIVE CD ROM : NOSE ASSEMBLY TABLE

## 202V

### Some Fastener and Nose Assemblies for use with the 202V Tool

Type	Diameter	Nose Assembly
MAGNA-LOK	4.8 mm (3/16")	99-3300, <b>99-3303</b> 99-3304
	6.4 mm (1/4")	99-3301, <b>99-3305</b> 99-3306, 99-3478 (H'Duty)
MAGNA-BULB	4.8 mm (3/16")	99-3300, <b>99-3303</b> 99-3304
	6.4 mm (1/4")	99-3301, <b>99-3305</b> 99-3306, 99-3478 (H'Duty)
AUTO-BULB	4.8 mm (3/16")	99-3300, <b>99-3303</b> 99-3304
	6.4 mm (1/4")	99-3301, <b>99-3305</b> 99-3306, 99-3478 (H'Duty)
MAGNA-TITE	4.8 mm (3/16")	99-3487-6MT
	6.4 mm (1/4")	99-3487-8MT
HUCKLOK	6.4 mm (1/4")	99-3301, <b>99-3305</b> 99-3306, 99-3478 (H'Duty)

Items in **bold** are part of our FOCUS Tooling Range