

AEROSPACE

ULTRALITE® COMPRESSION RIVETER C-Yoke Model 745

Standard Features

- Safety approved throttle lever
- Anodized aluminum housing
 - 90° elbow swivel air inlet
- Tool steel roller bearing and shaft
- Rivet capacity up to 5/16" aluminum and 1/4" steel
 - Additional configurations of C-yokes available
 - Operate on 90 PSI air
 - Smooth controlled throttle movement
- Set holders available in 3/16" and 1/4" set holes
 - Adjustable type set holders are optional
 - Low cost replacement parts

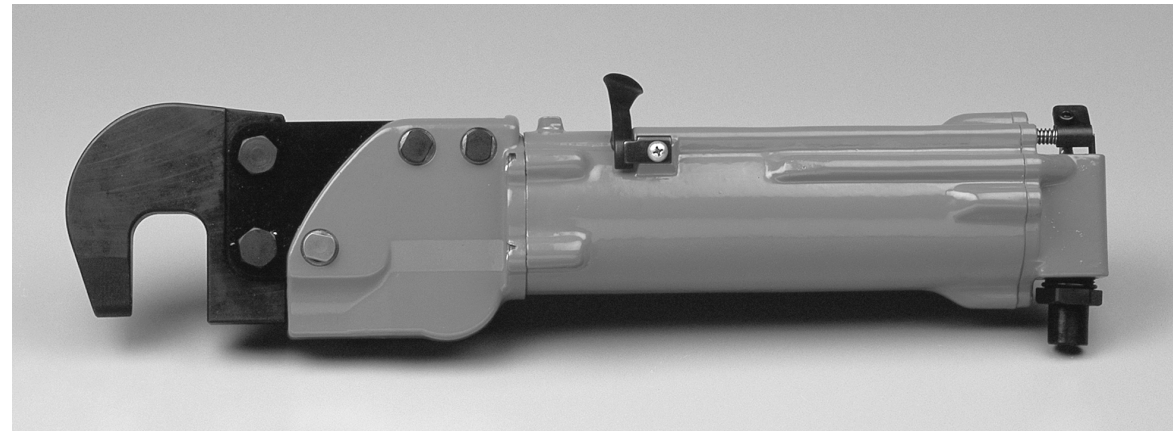

Power Unit

POWER UNIT ONLY		SET HOLDER PLUNGER				PART OF		NET WEIGHT		OVERALL		AIR	
MODEL NO.	ORDERING NO.	CAPACITY COLD RIVET		MAX FORCE AT 90 PSI		STROKE AT MAX FORCE		WITH C-YOKE		LENGTH		INLET	
		ALUMINUM	STEEL			in.	mm	lbs.	kg.	in.	mm	in.	
		in.	mm	in.	mm								
745	6532	5/16	7.9	1/4	6.4	10000		1/8	3.2	10	4.5	17-1/2 444	1/4 NPT

MINIMUM AIR PRESSURE: 90 PSI MINIMUM HOSE SIZE: 1/4" DIA.

Hi-Shear Corporation . 2600 Skypark Drive . Torrance, CA 90509 USA . tel 310.326.8110 . Tool Div. fax 310.784.4270
Hi-Shear Fasteners Europe Ltd. . Butlers Leap, Rugby . Warwickshire CV21 3RQ England . tel 0788.560916

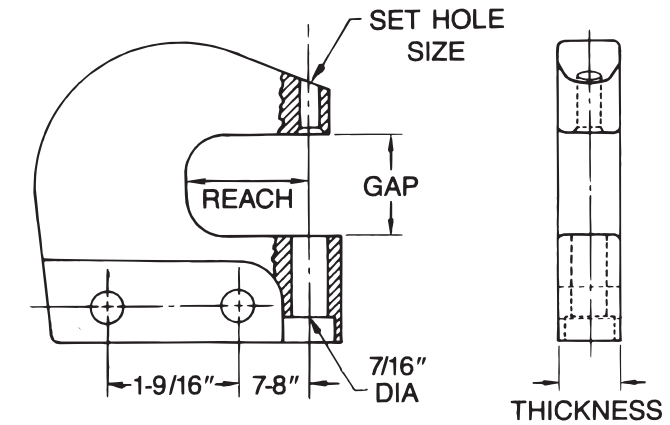
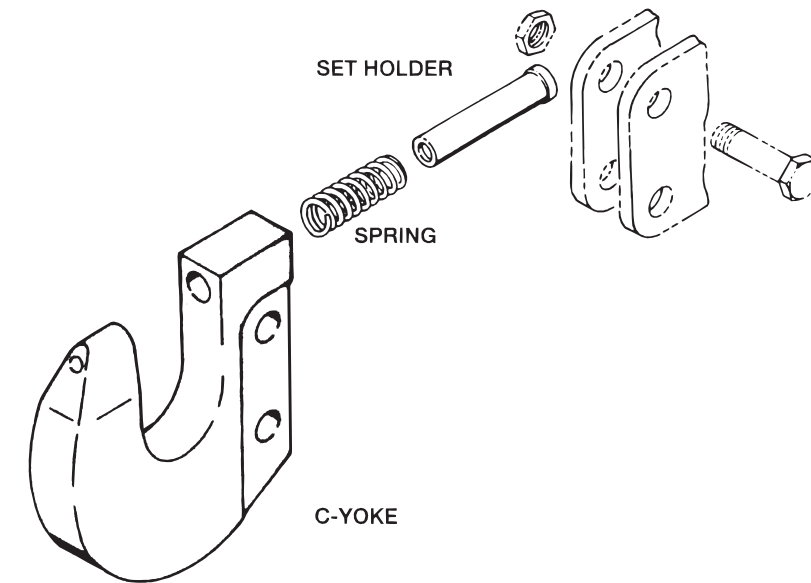

C-Yokes (dimensions in inches)

YOKE ASSY. NO.	REACH	GAP	THICKNESS	SET HOLE SIZE	SET HOLDER	SPRING
7479	1-1/2	1-1/4	3/4	3/16	7480	3054
7481	2	1-1/2	7/8	3/16	7480	3054
7482	3	1-1/2	1-1/8	3/16	7480	3054
7483	1-1/2	2	1	3/16	7480	3054
7484	2-1/2	1-3/8	1	3/16	7480	3054
7485	2-1/2	1-3/4	1-1/8	3/16	7480	3054
3052	1-1/2	1-1/4	3/4	1/4	3053	3054
6477	2	1-1/2	7/8	1/4	3053	3054
6478	3	1-1/2	1-1/8	1/4	3053	3054
6479	1-1/2	2	1	1/4	3053	3054
6480	2-1/2	1-3/8	1	1/4	3053	3054
6481	2-1/2	1-3/4	1-1/8	1/4	3053	3054

COMPRESSION RIVETER POWER UNIT - C-YOKE MODEL 745

Item	Part No.	Description	Qty.	Item	Part No.	Description	Qty.
005	3073	Cylinder	1	140	3084	. Valve, throttle	1
010	3081	Lever, throttle	1	145	3072	. O-ring	4
015	7275	Guard, safety, trigger	1	150	3078	. O-ring	1
020	6494	Screw, round hd	1	155	3096	Swivel, inlet	1
025	3069	Shaft, piston	1	160	2161	Spring, throttle valve	1
030	3063	Fork, shaft, piston	1	165	7509	Swivel nut assy., inlet	1
035	3062	Pin, roll	1	170	3095	. Nut, swivel, inlet	1
040	491	O-ring	2	175	2786	. O-ring	1
042	9819	Wedge assy.	1	180	3089	O-ring	1
043	9818	. Wedge	1	185	922	O-ring	1
044	J2732	. Pin	1	190	1065	Screw, soc hd cap	4
045	7771	Spring	1	195	3064	Bolt, pivot	1
050	3070	Piston assy.	2	200	1068	Nut, hex	3
055	3122	Nut, elastic stop	1	205	1067	Washer, flat	3
060	3075	Spacer	1	210	3060	Bolt	2
065	3090	O-ring	1	215	3068	Adapter, cylinder	1
070	3074	Retaining ring	2	220	541	Bolt	2
075	5730	O-ring	1	225	415	Nut	2
080	3093	Arm, lever, throttle	1	230	3057	Guard, roller, bearing	1
083	3077	Screw, soc hd cap	4	235	6507	Screw, slotted round hd	2
085	88	Screw, soc hd cap	1	240	3056	Plate, frame, yoke	2
090	200	Spring	1	245	3065	Lever, holder, set	1
095	2801	Roll pin	1	250	3101	Shaft, roller bearing	1
100	7123	Backhead assy.	1	255	3066	Roller, outer	1
105	3080	. Backhead	1	260	3100	Bearing, needle, roller	21
107	2082	. O-ring	4	265	3067	Guide, wedge	2
110	3083	. Bushing, valve, throttle	1	270	3058	Roller, outer	2
115	3079	Retaining ring	1	275	3059	Bearing, roller, needle	38
120	3087	Screen	1				
125	3085	Screen	1				
130	3088	Muffler	1				
135	3086	Valve assy., throttle	1				

