

AEROSPACE

ULTRALITE[®] COMPRESSION RIVETER

Alligator Model 750A

Standard Features

- Safety throttle lever
- Anodized aluminum housing
- 90° elbow swivel air inlet
- Rivet capacity up to 5/16" aluminum and 1/4" steel
 - Smooth controlled throttle movement
 - Low cost replacement parts
 - Tool steel roller bearings and shafts
- Additional configuration of jaws available
 - Operate on 90 PSI air
- Set holders in 3/16" and 1/4" diameter available

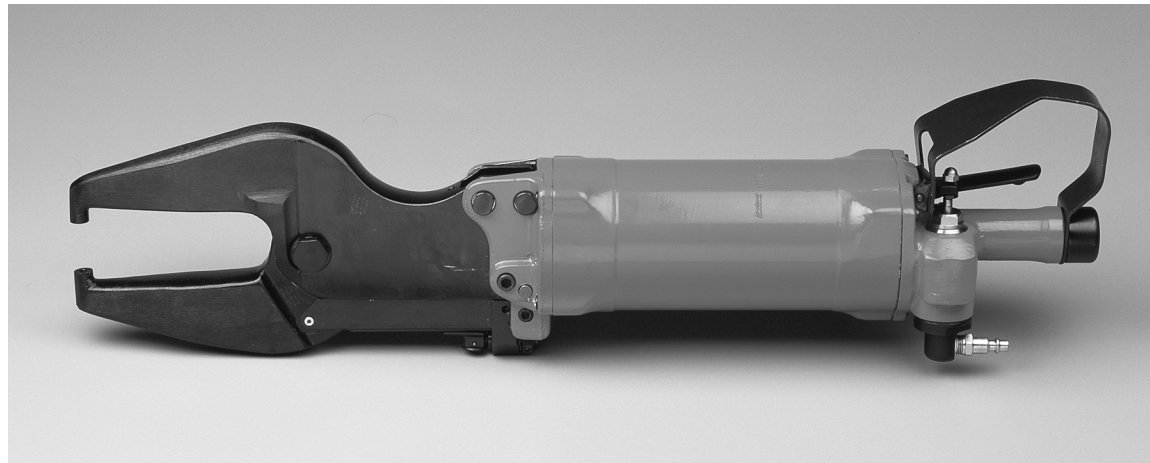

Power Unit

MODEL NO.	POWER UNIT ONLY		CAPACITY COLD RIVET				MAX FORCE AT 90 PSI pounds	PART OF STROKE AT MAX FORCE		NET WEIGHT WITH JAWS		OVERALL LENGTH		AIR INLET
	ORDERING NO.	JAW REACH	ALUMINUM	STEEL	in.	mm		in.	mm	lbs.	kg.	in.	mm	
750A	2087	2-7/8	5/16	7.9	1/4	6.4	16300	1/8	3.2	19	8.6	25	635	1/4 NPT
750A	2087	5	1/4	6.4	3/16	4.2	9390	3/16	4.8	24-1/4	11.0	27	685	1/4 NPT
750A	2087	7	3/16	4.8	5/32	4.0	6700	1/16	1.6	28	12.7	29	736	1/4 NPT
750A	2087	9-1/8	3/16	4.8	5/32	4.0	5140	1/16	1.6	29	13.1	31-1/8	790	1/4 NPT

MINIMUM AIR PRESSURE: 90 PSI

MINIMUM HOSE SIZE: 1/4" DIA.

Alligator Jaws See adjacent page →

Hi-Shear Corporation . 2600 Skypark Drive . Torrance, CA 90509 USA . tel 310.326.8110 . Tool Div. fax 310.784.4270
Hi-Shear Fasteners Europe Ltd. . Butlers Leap, Rugby . Warwickshire CV21 3RQ England . tel 0788.560916



Item	Part No.	Description	Qty.	Qty.	Qty.
				1769	1770
			2460	1767	1770
			6134	1768	1771
005	1090	Bolt	1	1	1
010	1091	Nut	1	1	1
015	5909	Shim	1	1	1
020	1341	Washer	2	2	2
025	1093	Bearing, needle	34	34	34
030	1092	Bearing, roller	1	1	1
035	16716	Roller assy.	1	1	
035	16680	Roller assy.			1
040	16551	. Race, outer	1	1	
040	16552	. Race, outer			1
045	626	. Bearing, needle	52	52	52
050	16550	. Race, inner	1	1	1
055	547	. Shaft	1	1	1
060	408	Washer	4	4	4
065	1088	Bearing, roller	2	2	2
070	1071	Bearing, needle	22	22	22
075	2641	Guard	1		
075	1749	Guard		1	
075	419	Guard			1
080	1089	Rivet	1	1	1
085	1223	Stud	1	1	1
090	230	Spring	1	1	1
095	1761	Screw	1	1	1
100	1756	Wheel	1	1	1
105	1754	Ring	1	1	1
110	1755	Washer	1	1	1
112	1764	Pin	1	1	1
115	1758	Washer	1	1	1
120	1760	Sleeve	1	1	1
125	1757	Pin	1	1	1
130	1759	Yoke	1	1	1
135	1219	Pin	1	1	1
140	1762	Button	1	1	1
145	1763	Spring	1	1	1
150	1748	Guard	1	1	1
155	1075	Screw	1	1	1

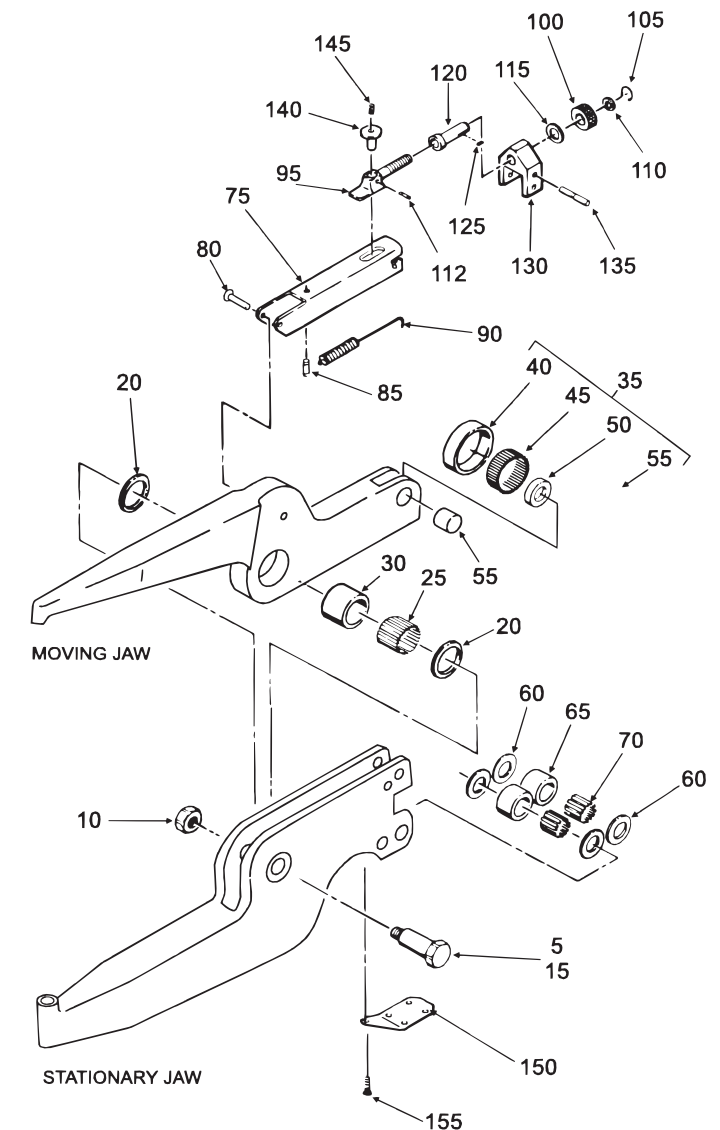

Alligator Jaws

JAW ASSY.	STATIONARY JAW	MOVING JAW	SET HOLE SIZE	REACH	CLOSED HEIGHT	MAX. TRAVEL	GAP	OFFSET
2460	2459	2461	3/16	2-7/8	7/8	13/16	1-5/8	3/8
6134	6131	6132	1/4	2-7/8	7/8	13/16	1-5/8	3/8
1767	1744	1745	3/16	5	7/8	1-3/8	1-5/8	3/8
1768	1765	1766	1/4	5	7/8	1-3/8	1-5/8	3/8
1769	582	581	3/16	7	3/4	1-7/8	2-1/8	11/16
1770	1136	1137	1/4	7	3/4	1-7/8	2-1/8	11/16
449	414	549	3/16	9-1/8	3/4	2-1/2	2-1/8	11/16
1771	1274	1275	1/4	9-1/8	3/4	2-1/2	2-1/8	11/16

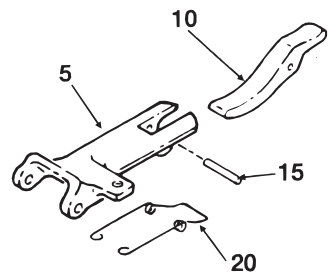

Option -
2318 Safety Lever Assy

005	2313	Lever	1
010	2315	Lever	1
015	1000	Pin	1
020	2314	Spring	1

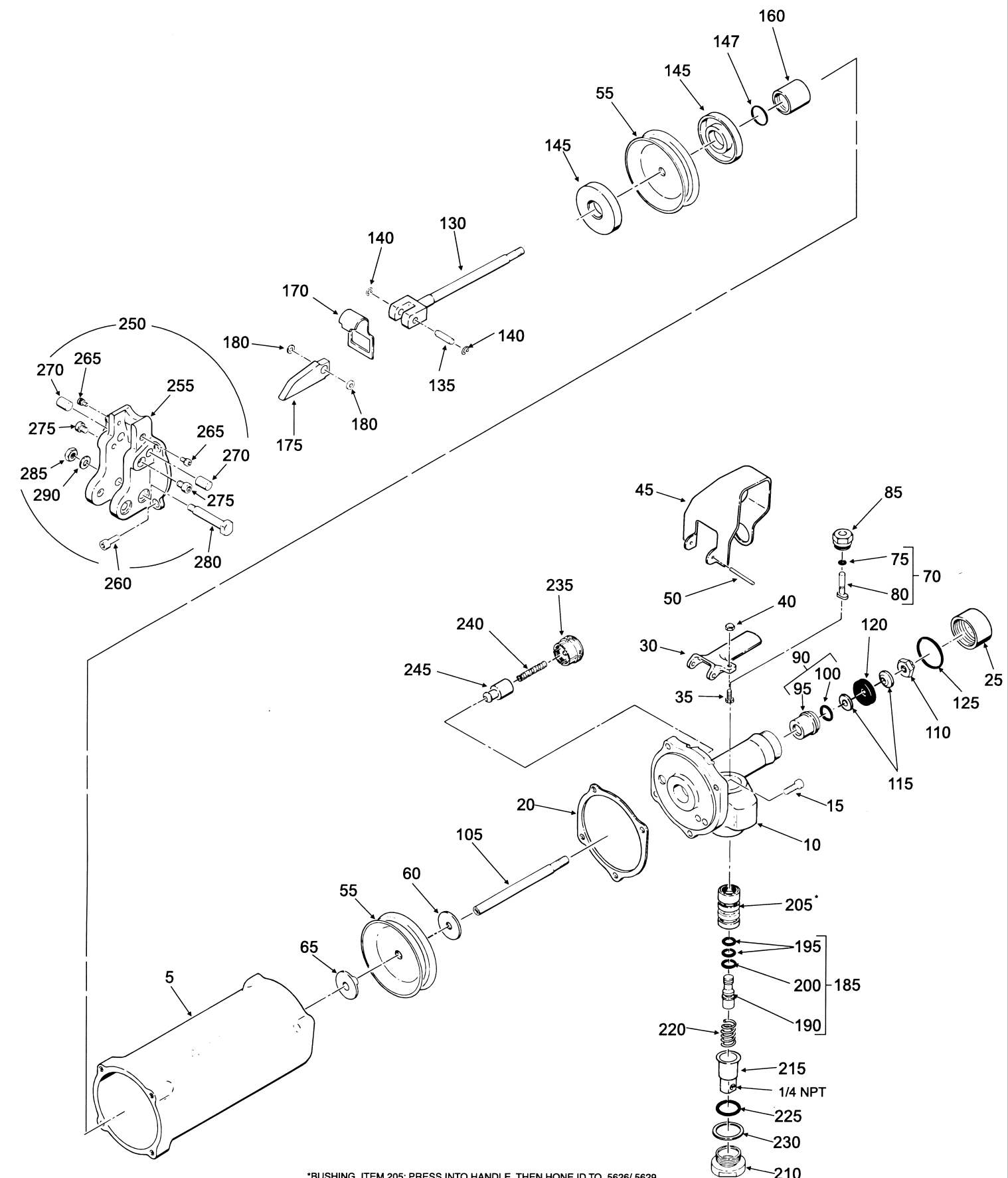

*BUSHING, ITEM 205: PRESS INTO HANDLE, THEN HONE ID TO .5626/.5629.

COMPRESSION RIVETER POWER UNIT - ALLIGATOR JAW MODEL 750A

Item	Part No.	Description	Qty.	Item	Part No.	Description	Qty.
005	2064	Cylinder	1	145	2079	Spacer	2
010	5649	Handle assy.	1	147	922	O-ring	1
015	1065	Screw, soc hd cap	4	160	295	Bushing	1
020	2070	Gasket, cylinder head	1	170	2061	Spring	1
025	2316	Plug, return cylinder	1	175	560	Wedge	1
030	1484	Lever	1	180	561	Shim, stamping	2
035	409	Screw, adjusting, slotted	1	185	2080	Valve assy., throttle	1
040	401	Nut, hex, acorn	1	190	2490	. Valve, throttle	1
045	2430	Guard	1	195	2266	. O-ring	2
050	3129	Dowel pin	1	200	548	. O-ring	1
055	2071	Piston	2	205	406	Bushing	1
060	2075	Spacer	1	210	1079	Nut, swivel, air inlet	1
065	2073	Bushing, flange	1	215	1145	Swivel, air inlet	1
070	2081	Push pin assy.	1	220	1080	Spring, valve, throttle	1
075	564	. O-ring	1	225	1228	O-ring	1
080	2491	. Push pin, throttle valve	1	230	402	Gasket	1
085	403	Bushing	1	235	1127	Nut, adjustable	1
090	1094	Bushing assy.	1	240	1101	Spring, compression	1
095	2501	. Bushing, flange	1	245	1100	Valve, exhaust	1
100	922	. O-ring	1	250	17076	Adapter assy.	1
105	2077	Shaft, piston	1	255	6785	. Adapter	1
110	2322	Nut, elastic stop	1	260	1065	. Screw	4
115	2067	Washer, cone	2	265	1099	. Screw	2
120	2084	Piston, return	1	270	1084	. Pin	2
125	151	O-ring	1	275	1085	. Screw	2
130	2068	Fork, shaft, piston	1	280	1086	. Bolt	2
135	1095	Dowel pin	1	285	975	. Nut	2
140	551	Ring, locking	2	290	1087	. Washer	2