

# AEROSPACE

## ULTRALITE® COMPRESSION RIVETER

### Alligator Model 745A

#### Standard Features

- Safety throttle lever
- Anodized aluminum housing
- 90° elbow swivel air inlet
- Rivet capacity up to 3/16" aluminum and 5/32" steel
- Smooth controlled throttle movement
- Low cost replacement parts
- Tool steel roller bearings and shafts
- Additional configuration of jaws available
- Operate on 90 PSI air
- Set holders in 3/16" and 1/4" diameter available

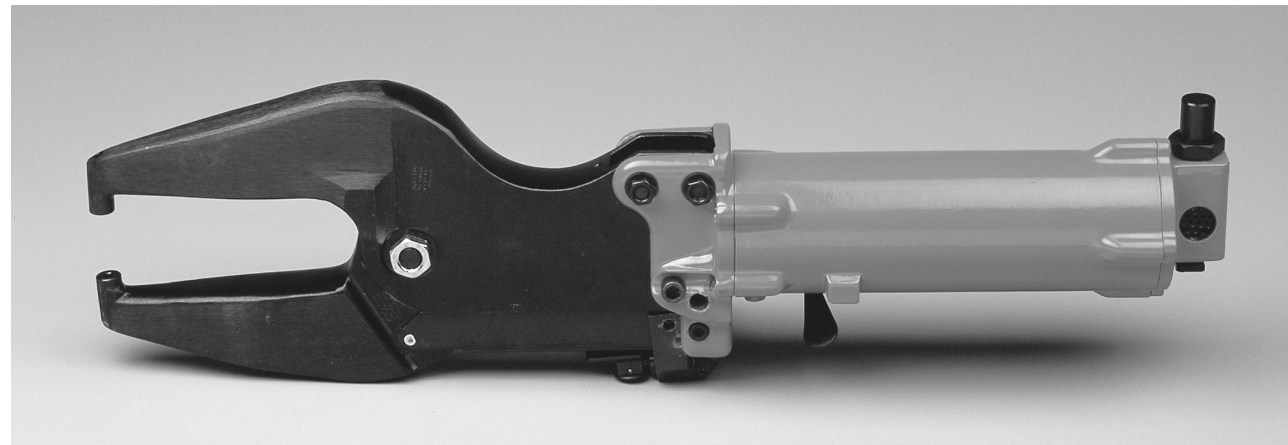

#### Power Unit

POWER UNIT ONLY MODEL NO.	ORDERING NO.	JAW REACH	CAPACITY COLD RIVET		MAX FORCE AT 90 PSI pounds	STROKE AT MAX FORCE		NET WEIGHT WITH JAWS		OVERALL LENGTH		AIR INLET in.
			ALUMINUM in.	STEEL mm		in.	mm	lbs.	kg.	in.	mm	
745A	9476	2-7/8	3/16	4.8	6000	1/16	1.6	13	5.9	17-1/2	444	1/4 NPT
745A	9476	5	5/32	4.0	3450	1/16	1.6	16	7.2	22-1/2	571	1/4 NPT

MINIMUM AIR PRESSURE: 90 PSI

MINIMUM HOSE SIZE: 1/4" DIA.

Hi-Shear Corporation . 2600 Skypark Drive . Torrance, CA 90509 USA . tel 310.326.8110 . Tool Div. fax 310.784.4270  
Hi-Shear Fasteners Europe Ltd. . Butlers Leap, Rugby . Warwickshire CV21 3RQ England . tel 0788.560916



Item	Part No.	Description	Qty.	Qty.	Qty.
				1769	1770
			2460	1767	449
			6134	1768	1771
005	1090	Bolt	1	1	1
010	1091	Nut	1	1	1
015	5909	Shim	1	1	1
020	1341	Washer	2	2	2
025	1093	Bearing, needle	34	34	34
030	1092	Bearing, roller	1	1	1
035	16716	Roller assy.	1	1	
035	16680	Roller assy.			1
040	16551	. Race, outer	1	1	
040	16552	. Race, outer			1
045	626	. Bearing, needle	52	52	52
050	16550	. Race, inner	1	1	1
055	547	. Shaft	1	1	1
060	408	Washer	4	4	4
065	1088	Bearing, roller	2	2	2
070	1071	Bearing, needle	22	22	22
075	2641	Guard	1		
075	1749	Guard		1	
075	419	Guard			1
080	1089	Rivet	1	1	1
085	1223	Stud	1	1	1
090	230	Spring	1	1	1
095	1761	Screw	1	1	1
100	1756	Wheel	1	1	1
105	1754	Ring	1	1	1
110	1755	Washer	1	1	1
112	1764	Pin	1	1	1
115	1758	Washer	1	1	1
120	1760	Sleeve	1	1	1
125	1757	Pin	1	1	1
130	1759	Yoke	1	1	1
135	1219	Pin	1	1	1
140	1762	Button	1	1	1
145	1763	Spring	1	1	1
150	1748	Guard	1	1	1
155	1075	Screw	1	1	1

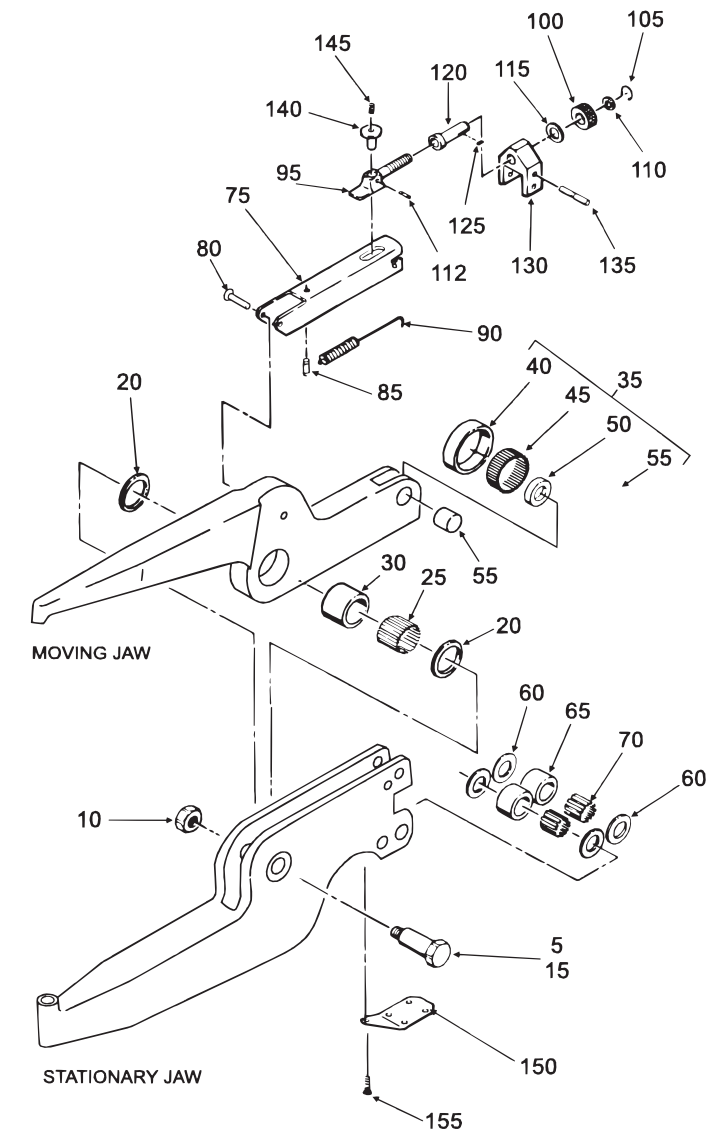

#### Alligator Jaws

JAW ASSY.	STATIONARY JAW	MOVING JAW	SET HOLE SIZE	REACH	CLOSED HEIGHT	MAX. TRAVEL	GAP	OFFSET
2460	2459	2461	3/16	2-7/8	7/8	13/16	1-5/8	3/8
6134	6131	6132	1/4	2-7/8	7/8	13/16	1-5/8	3/8
1767	1744	1745	3/16	5	7/8	1-3/8	1-5/8	3/8
1768	1765	1766	1/4	5	7/8	1-3/8	1-5/8	3/8
1769	582	581	3/16	7	3/4	1-7/8	2-1/8	11/16
1770	1136	1137	1/4	7	3/4	1-7/8	2-1/8	11/16
449	414	549	3/16	9-1/8	3/4	2-1/2	2-1/8	11/16
1771	1274	1275	1/4	9-1/8	3/4	2-1/2	2-1/8	11/16

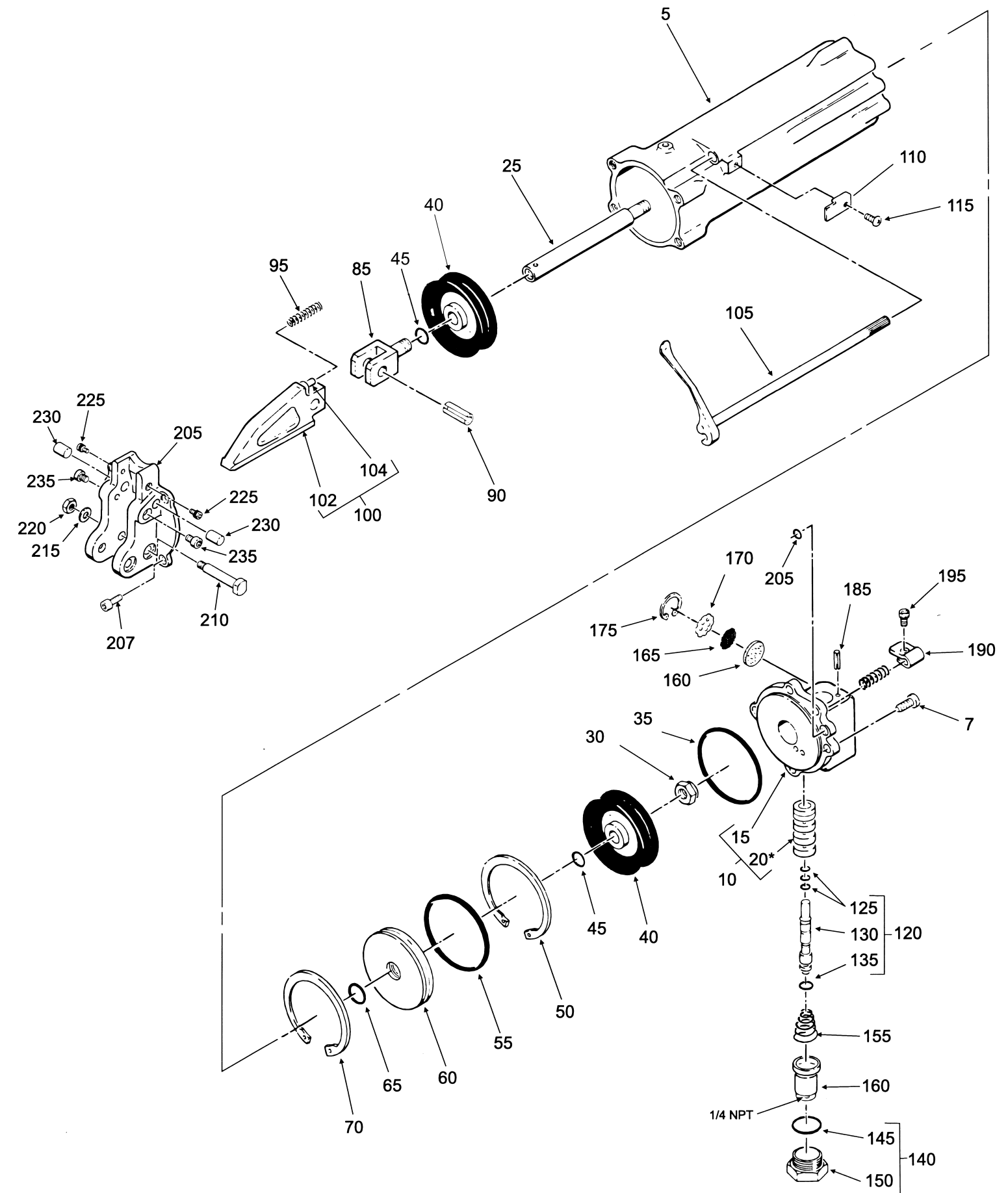

\*BUSHING, ITEM 20: PRESS INTO HANDLE, THEN HONE ID TO .5626/.5629

**COMPRESSION RIVETER POWER UNIT - ALLIGATOR JAW MODEL 745A**

Item	Part No.	Description	Qty.	Item	Part No.	Description	Qty.
005	3073	Cylinder	1	130	3084	Valve, throttle	1
007	3077	Screw, soc hd cap	4	135	3078	O-ring	1
010	7123	Backhead assy.	1	140	7509	Swivel nut assy., inlet	1
015	3080	Backhead	1	145	2786	O-ring	1
020	3083	Bushing, valve, throttle	1	150	3095	Inlet, swivel nut	1
025	3069	Piston shaft	1	155	2161	Spring, throttle valve	1
030	3122	Nut, elastic stop	1	160	3088	Muffler	1
035	5730	O-ring	1	162	3096	Swivel, inlet	1
040	3070	Piston assy., double acting	2	165	3087	Screen	1
045	491	O-ring	2	170	3085	Screen	1
050	3074	Retainng ring	2	175	3079	Retainng ring	1
055	3090	O-ring	1	180	3089	O-ring	1
060	3075	Spacer	1	185	2801	Roll pin	1
065	922	O-ring	1	190	3093	Arm, lever, throttle	1
085	3063	Fork, shaft piston	1	195	88	Screw, soc hd cap	1
090	3062	Roll pin	1	200	200	Spring	1
095	7771	Spring	1	205	6785	Adapter, cylinder	1
100	9819	Wedge assy.	1	207	1065	Screw, soc hd cap	4
102	9818	. Wedge	1	210	1086	Bolt, roller, bearing	2
104	J2732	. Pin	1	215	1087	Washer, flat	2
105	3081	Lever, throttle	1	220	975	Nut, hex	2
110	7275	Guard, safety, trigger	1	225	1099	Screw, soc hd cap	2
115	6494	Screw, round hd	1	230	1084	Dowel pin	2
120	3086	Valve assy., throttle	1	235	1085	Screw, soc hd cap	2
125	3072	O-ring	3				