

NUTPLATE MEETS THE STRENGTH REQUIREMENTS OF MIL-N-25027

NUTPLATE ATTACHED BY MEANS OF ADHESIVE APPLIED TO THIS SURFACE

DISPOSABLE ELASTIC FIXTURE HOLDS NUTPLATE WHILE ADHESIVE CURES



NOTE: ALL DIMENSIONS BEFORE PAINT

PART NUMBER	THREAD T	A MAX	B MAX	D MIN	H MAX	R MIN
CB9186 () 08 () 1	.1640-32 UNJC-3B	.745	.454	.224	.250	.070
CB9186 () 324 () 1	.1900-24 UNJC-3B	.745	.454	.250	.250	.070
CB9186 () 324 () 2					.312	.125
CB9186 () 324 () 3					.375	.188
CB9186 () 324 () 4					.438	.250
CB9186 () 324 () 5					.502	.313
CB9186 () 324 () 6					.564	.375
CB9186 () 420 () 1	.2500-20 UNJC-3B	.948	.554	.312	.295	.070
CB9186 () 420 () 2					.357	.125
CB9186 () 420 () 3					.419	.188
CB9186 () 420 () 4					.481	.250
CB9186 () 420 () 5					.543	.313
CB9186 () 420 () 6					.605	.375
CB9186 () 518 () 1	.3125-18 UNJC-3B	1.042	.650	.375	.338	.070
CB9186 () 518 () 2					.394	.125
CB9186 () 518 () 3					.455	.188
CB9186 () 518 () 4					.524	.250
CB9186 () 518 () 5					.586	.313
CB9186 () 518 () 6					.649	.375
CB9186 () 616 () 1	.3750-16 UNJC-3B	1.182	.750	.437	.375	.070
CB9186 () 616 () 2					.425	.125
CB9186 () 714 () 1	.4375-14 UNJC-3B	1.307	.840	.500	.500	.070
CB9186 () 813 () 1	.5000-13 UNJC-3B	1.432	.900	.562	.580	.070

EXAMPLE PART NUMBER

CB9186 CR 324 - 1 P

OPTIONAL PRIMER COATING ON BASEPLATE
 THREAD RELIEF R - .070 MIN
 NUT MATERIAL - A-286 CRES
 THREAD T SIZE - .1900-24 UNJC-3B
 BASEPLATE MATERIAL - A-286 CRES
 BASIC PART NUMBER

UNLESS OTHERWISE SPECIFIED, ALL DIMENSIONS ARE IN INCHES AND TOLERANCES ARE AS SHOWN BELOW. DIMENSIONAL TOLERANCES AND SYMBOLS PER ANSI Y14.5M-1982.

PROPRIETARY PARTS SHOWN IN THIS DRAWING ARE THE SUBJECT OF ISSUED UNITED STATES AND FOREIGN PATENTS AND PATENTS PENDING. UNAUTHORIZED REPRODUCTION AND/OR DISTRIBUTION OF THIS DRAWING IS SPECIFICALLY PROHIBITED.

GLICK BOND

CARSON CITY
NEVADA 89706

CAD CB9186-1		APPROVALS		DATE	TITLE			
ANGLES	±1°	DRAWN	DAC	13JAN98	NUTPLATE, TWO LUG, BONDED, COARSE THREAD			
.XX	±.03	CHECKED	DAC	13JAN98	SIZE	CAGE CODE	DWG. NO.	
.XXX	±.010	RELEASED	CGH	14JAN98	A	66530	CB9186	
.XXXX	±.001	REVISED			SCALE	2/1	13JAN98	
							SHEET	1 OF 2

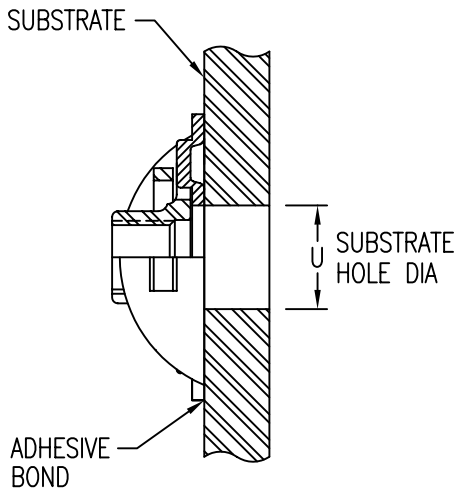

INSTALLATION HOLE SIZE

THD SIZE CODE	U MAX
08	.224
324	.250
420	.312
518	.375
616	.437
714	.500
813	.562

BASEPLATE MATERIAL AND FINISH DATA

CODE	MATERIAL	SPECIFICATION	FINISH	SPECIFICATION
A	ALUMINUM	QQ-A-250	NONE	
AA	ALUMINUM	QQ-A-250	ANODIZE	MIL-A-8625, TY 1
CR	A-286 CRES	AMS 5525	PASSIVATE	QQ-P-35

OPTIONAL PRIMER COATING ON BASEPLATE: EPOXY PRIMER PER MIL-P-85582.

NUT MATERIAL AND FINISH DATA

CODE	MATERIAL	FINISH	SPECIFICATION	DRI-FILM LUBE
-	A-286 CRES	PASSIVATE	QQ-P-35	MIL-L-46010 TY 1
CRC	A-286 CRES	CAD PLATE	QQ-P-416	MIL-L-46010 TY 1
CRS	A-286 CRES	SILVER PLATE	AMS 2410	NONE

RETAINING CLIP MATERIAL AND FINISH: 302 CRES OR 18-2MN CRES, PASSIVATE PER QQ-P-35.

UNLESS OTHERWISE SPECIFIED, ALL DIMENSIONS ARE IN INCHES AND TOLERANCES ARE AS SHOWN BELOW. DIMENSIONAL TOLERANCES AND SYMBOLS PER ANSI Y14.5M-1982.

PROPRIETARY PARTS SHOWN IN THIS DRAWING ARE THE SUBJECT OF ISSUED UNITED STATES AND FOREIGN PATENTS AND PATENTS PENDING. UNAUTHORIZED REPRODUCTION AND/OR DISTRIBUTION OF THIS DRAWING IS SPECIFICALLY PROHIBITED.

GLICK BOND

CARSON CITY
NEVADA 89706

CAD CB9186-2

APPROVALS	DATE
DRAWN DAC	13JAN98
CHECKED DAC	13JAN98
RELEASED CGH	14JAN98
REVISED	

TITLE
NUTPLATE, TWO LUG, BONDED, COARSE THREAD

SIZE	CAGE CODE	DWG. NO.	REV.
A	66530	CB9186	0

SCALE	DATE	SHEET	OF	TOTAL
2/1	13JAN98	2	OF	2