

CB6002 CLIP CAN BE REMOVED WITH PLIERS TO REPLACE NUT.

NUTPLATE MEETS THE STRENGTH REQUIREMENTS OF NASM25027.

NOTE: ALL DIMENSIONS BEFORE PAINT.

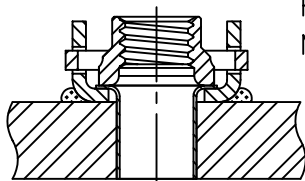

DI INSIDE SLEEVE DIA AFTER EXPANSION

TYPICAL COMPLETED INSTALLATION

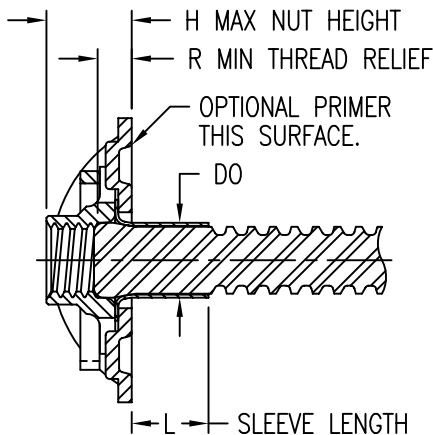

SLEEVE THICKNESS .008 REF.

DH SUBSTRATE HOLE DIA

NUTPLATE ATTACHED BY ADHESIVE APPLIED TO THIS SURFACE.

DISPOSABLE MANDREL EXPANDS SLEEVE.

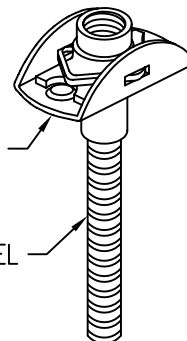

NUTPLATE DIMENSIONS

SLEEVE EXPANSION (DI FINAL) BASED ON HIGH STRENGTH ALUMINUM SUBSTRATE.

PART NUMBER	THREAD T	A MAX	B MAX	DI	DO REF	H MAX	R MIN	DH
CB6309 ( ) 3 ( ) 1 ( ) ( )	.1900-32 UNJF-3B	.745	.454	.194	.195	.265	.070	.2010
CB6309 ( ) 3 ( ) 2 ( ) ( )						.327	.125	
CB6309 ( ) 3 ( ) 3 ( ) ( )						.390	.188	
CB6309 ( ) 3 ( ) 4 ( ) ( )						.453	.250	
CB6309 ( ) 3 ( ) 5 ( ) ( )						.517	.313	
CB6309 ( ) 3 ( ) 6 ( ) ( )						.579	.375	
CB6309 ( ) 4 ( ) 1 ( ) ( )	.2500-28 UNJF-3B	.948	.554	.254	.255	.310	.070	.2570
CB6309 ( ) 4 ( ) 2 ( ) ( )						.372	.125	
CB6309 ( ) 4 ( ) 3 ( ) ( )						.434	.188	
CB6309 ( ) 4 ( ) 4 ( ) ( )						.496	.250	
CB6309 ( ) 4 ( ) 5 ( ) ( )						.558	.313	
CB6309 ( ) 4 ( ) 6 ( ) ( )						.620	.375	

EXAMPLE PART NUMBER

CB6309 CR 3 - 1 P 200

"NL" SUFFIX TO PART NUMBER INDICATES NON-LOCKING NUT ELEMENT.

- OPTIONAL FINISH ON SLEEVE - PASSIVATE
- SLEEVE LENGTH L IN THOUSANDTHS - .200
- OPTIONAL PRIMER COATING ON BASEPLATE
- THREAD RELIEF R - .070 MIN
- NUT MATERIAL - A-286 CRES, DRI-FILM LUBE
- THREAD T SIZE - .1900-32 UNJF-3B
- BASEPLATE MATERIAL - A-286 CRES
- BASIC PART NUMBER

UNLESS OTHERWISE SPECIFIED, ALL DIMENSIONS ARE IN INCHES AND TOLERANCES ARE AS SHOWN BELOW. DIMENSIONAL TOLERANCES AND SYMBOLS PER ANSI Y14.5M-1982.

FLEX FIT  
CAD CB6309-1

PROPRIETARY PARTS SHOWN IN THIS DRAWING ARE THE SUBJECT OF ISSUED UNITED STATES AND FOREIGN PATENTS AND PATENTS PENDING. UNAUTHORIZED REPRODUCTION AND/OR DISTRIBUTION OF THIS DRAWING IS SPECIFICALLY PROHIBITED.

**GLICK BOND**

CARSON CITY  
NEVADA 89706

APPROVALS		DATE
DRAWN	DAC	15JUL02
CHECKED	DAC	15JUL02
RELEASED	CGH	15JUL02
REVISED	DAC	15JUL02

TITLE			
NUTPLATE, TWO LUG, FLEX SLEEVE			
SIZE	CAGE CODE	DWG. NO.	REV.
A	66530	CB6309	4
SCALE	2/1 15JUL02		SHEET 1 OF 3

REPLACEMENT COMPONENT PART NUMBERS

THREAD SIZE CODE	NUT PART NO *	CLIP PART NO
3	CB6001 ( ) 3-( )	CB6002-3
4	CB6001 ( ) 4-( )	CB6002-4

\* FIRST ( ) DESIGNATES NUT MATERIAL CODE.

CR = A-286 CRES, PASSIVATE, DRI-FILM LUBE.

CRC = A-286 CRES, CADMIUM PLATING, DRI-FILM LUBE.

CRS = A-286 CRES, SILVER PLATING.

SECOND ( ) DESIGNATES NUTPLATE THREAD RELIEF (NUT C'BORE) CODE.

"NL" SUFFIX TO NUT PART NO. INDICATES NON-LOCKING NUT ELEMENT.

BASEPLATE MATERIAL AND FINISH DATA

CODE	MATERIAL	SPEC.	FINISH	SPEC.
A	ALUMINUM	QQ-A-250	NONE	
AA	ALUMINUM	QQ-A-250	ANODIZE	MIL-A-8625, TY 1
CR	A-286 CRES	AMS 5525	PASSIVATE	QQ-P-35

OPTIONAL PRIMER COATING ON BASEPLATE: EPOXY PRIMER PER MIL-P-85582.

NUT MATERIAL AND FINISH DATA (SEE CB6001)

CODE	MATERIAL	FINISH	SPEC.	LUBRICATION	SPEC.
-	A-286 CRES	PASSIVATE	QQ-P-35	DRI-FILM LUBE	MIL-L-46010, TY 1
CRC	A-286 CRES	CADMIUM PLATING	QQ-P-416	DRI-FILM LUBE	MIL-L-46010, TY 1
CRS	A-286 CRES	SILVER PLATING	AMS 2410	NONE	

SLEEVE MATERIAL AND FINISH DATA

CODE	MATERIAL	SPEC.	FINISH	SPEC.
NONE	A-286 CRES	AMS 5525 OR 5639	PASSIVATE	QQ-P-35
A	A-286 CRES	AMS 5525 OR 5639	IVD ALUMINUM	MIL-DTL-83488
C	A-286 CRES	AMS 5525 OR 5639	CAD PLATE	QQ-P-416

CLIP MATERIAL AND FINISH DATA:

MATERIAL: 302 CRES PER AMS 5688 OR 5866, OR  
18-2 MN CRES PER ARMC0 SPEC. (SEE CB6002)

FINISH: PASSIVATE PER QQ-P-35. (SEE CB6002)

UNLESS OTHERWISE SPECIFIED, ALL DIMENSIONS ARE IN INCHES AND TOLERANCES ARE AS SHOWN BELOW. DIMENSIONAL TOLERANCES AND SYMBOLS PER ANSI Y14.5M-1982.

FLEX FIT  
CAD CB6309-2

PROPRIETARY PARTS SHOWN IN THIS DRAWING ARE THE SUBJECT OF ISSUED UNITED STATES AND FOREIGN PATENTS AND PATENTS PENDING. UNAUTHORIZED REPRODUCTION AND/OR DISTRIBUTION OF THIS DRAWING IS SPECIFICALLY PROHIBITED.

**GLICK BOND**

CARSON CITY  
NEVADA 89706

APPROVALS		DATE	TITLE		
DRAWN	DAC	15JUL02	NUTPLATE, TWO LUG, FLEX SLEEVE		
CHECKED	DAC	15JUL02	SIZE	CAGE CODE	DWG. NO.
RELEASED	CGH	15JUL02	A	66530	CB6309
REVISED	DAC	15JUL02	SCALE	2/1	15JUL02
					SHEET 2 OF 3
					REV. 4

1. DRILL HOLE IN SUBSTRATE AND CHECK DH WITH PLUG GAGE.

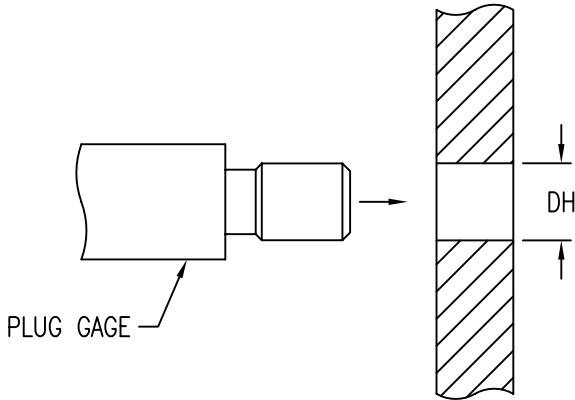

2. APPLY MIXED ADHESIVE TO NUTPLATE BASEPLATE AND PASS MANDREL THROUGH SUBSTRATE HOLE.

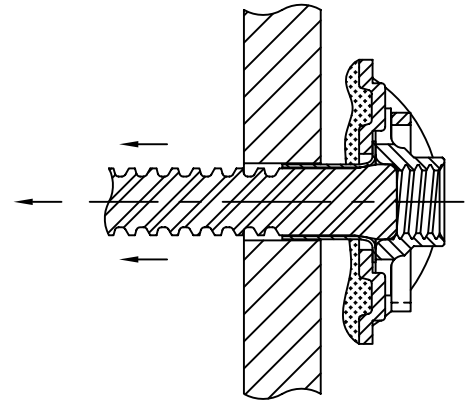

3. PLACE PULL TOOL OVER MANDREL AND ROTATE NUTPLATE TO DESIRED ORIENTATION.

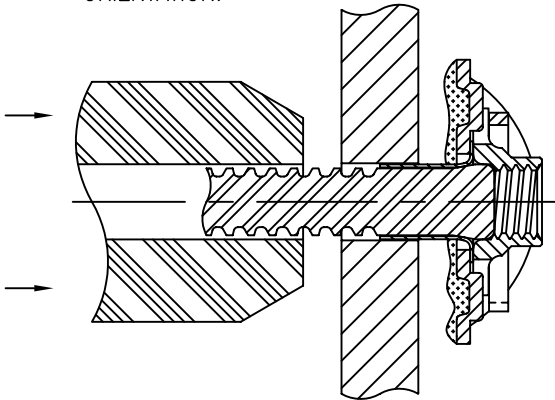

4. ACTUATE TOOL TO PULL MANDREL.

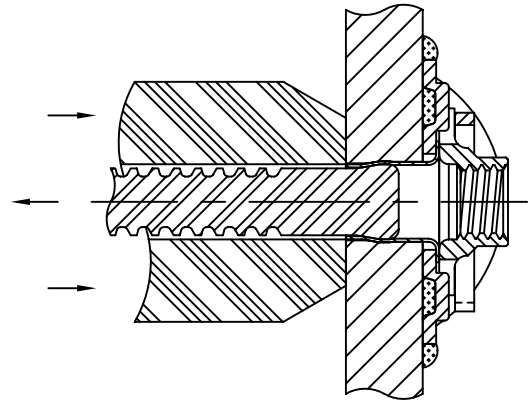

5. MANDREL PULLS THROUGH SLEEVE EXPANDING SLEEVE AND SUBSTRATE HOLE.

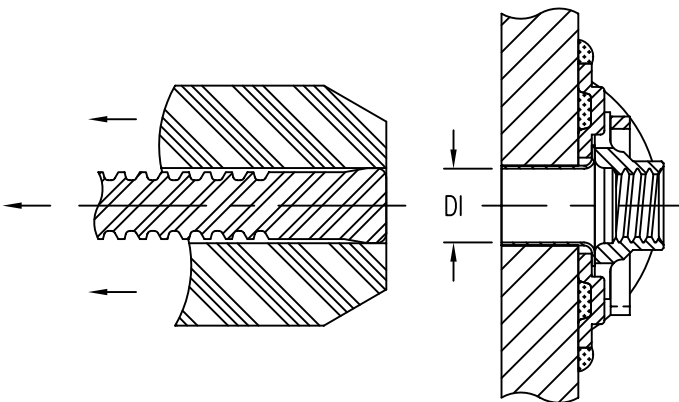

6. CHECK SLEEVE INSIDE DIAMETER DI WITH PLUG GAGE.

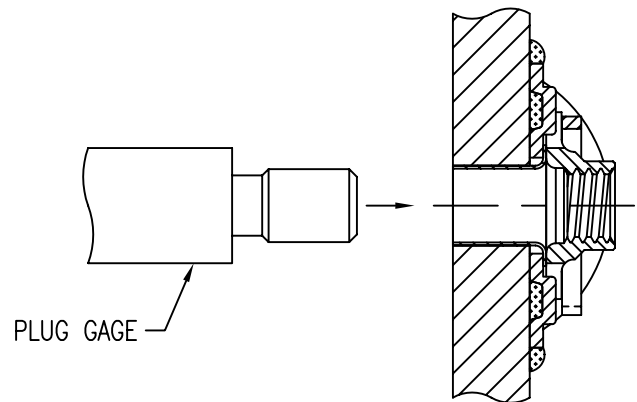

UNLESS OTHERWISE SPECIFIED, ALL DIMENSIONS ARE IN INCHES AND TOLERANCES ARE AS SHOWN BELOW. DIMENSIONAL TOLERANCES AND SYMBOLS PER ANSI Y14.5M-1982.

FLEX FIT  
CAD CB6309-3

PROPRIETARY PARTS SHOWN IN THIS DRAWING ARE THE SUBJECT OF ISSUED UNITED STATES AND FOREIGN PATENTS AND PATENTS PENDING. UNAUTHORIZED REPRODUCTION AND/OR DISTRIBUTION OF THIS DRAWING IS SPECIFICALLY PROHIBITED.

**CLICK BOND**

CARSON CITY  
NEVADA 89706

APPROVALS		DATE	
DRAWN	DAC	15JUL02	
CHECKED	DAC	15JUL02	
RELEASED	CGH	15JUL02	
REVISED	DAC	15JUL02	

TITLE			
NUTPLATE, TWO LUG, FLEX SLEEVE			
SIZE	CAGE CODE	DWG. NO.	REV.
A	66530	CB6309	4
SCALE	2/1		15JUL02
SHEET 3 OF 3			