

NUTPLATES WITH COUNTERBORED NUTS OTHER THAN STANDARD (2 CODE) ARE MARKED WITH PAINT DOT COLOR CODE ON TOP OF THE DOME.

NOTE: ALL DIMENSIONS BEFORE PAINT.

NUTPLATE MEETS THE STRENGTH REQUIREMENTS OF MIL-N-25027.

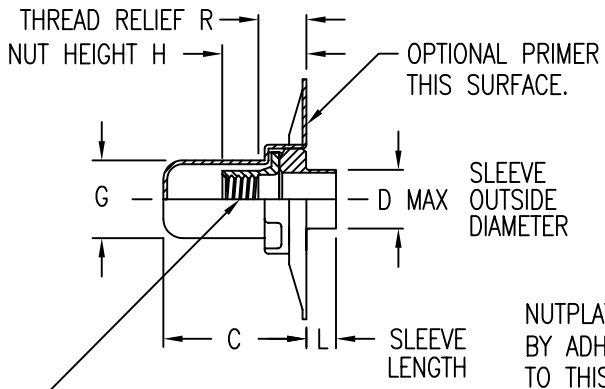

THREAD T
RADIAL FLOAT OF NUT ELEMENT .020 MIN. FROM CENTER LINE IN ANY DIRECTION. THREAD LOCK PER MIL-N-25027.

NUTPLATE ATTACHED BY ADHESIVE APPLIED TO THIS SURFACE.

DISPOSABLE FIXTURE RING

DISPOSABLE ELASTIC FIXTURE HOLDS NUTPLATE WHILE ADHESIVE CURES.

PART NUMBER	THREAD T	A MAX	B MAX	C MAX	D MAX	F MAX	G MAX	H MAX	R MIN	COLOR CODE
CB6210 () 3 () 2 P () ()	.1900-32 UNJF-3B	.995	.580	.687	.250	.800	.350	.330	.125	NONE
CB6210 () 3 () 3 P () ()								.375	.187	RED
CB6210 () 3 () 4 P () ()								.438	.250	GREEN
CB6210 () 3 () 5 P () ()				.937				.500	.312	BLACK
CB6210 () 3 () 6 P () ()								.563	.375	BLUE
CB6210 () 3 () 7 P () ()								.640	.437	ORANGE
CB6210 () 3 () 8 P () ()			.705	.500	PURPLE					
CB6210 () 4 () 2 P () ()	.2500-28 UNJF-3B	1.245	.725	.765	.312	.995	.450	.360	.125	NONE
CB6210 () 4 () 3 P () ()								.425	.187	RED
CB6210 () 4 () 4 P () ()								.490	.250	GREEN
CB6210 () 4 () 5 P () ()				1.025				.555	.312	BLACK
CB6210 () 4 () 6 P () ()								.620	.375	BLUE
CB6210 () 4 () 7 P () ()								.683	.437	ORANGE
CB6210 () 4 () 8 P () ()			.750	.500	PURPLE					
CB6210 () 5 () 2 P () ()	.3125-24 UNJF-3B	1.200	.807	.825	.375	1.050	.550	.450	.125	NONE
CB6210 () 5 () 3 P () ()								.512	.187	RED
CB6210 () 5 () 4 P () ()								.575	.250	GREEN
CB6210 () 5 () 5 P () ()				1.075				.586	.312	BLACK
CB6210 () 5 () 6 P () ()								.649	.375	BLUE
CB6210 () 5 () 7 P () ()								.711	.437	ORANGE
CB6210 () 5 () 8 P () ()			.774	.500	PURPLE					

UNLESS OTHERWISE SPECIFIED, ALL DIMENSIONS ARE IN INCHES AND TOLERANCES ARE AS SHOWN BELOW. DIMENSIONAL TOLERANCES AND SYMBOLS PER ANSI Y14.5M-1982.

PROPRIETARY PARTS SHOWN IN THIS DRAWING ARE THE SUBJECT OF ISSUED UNITED STATES AND FOREIGN PATENTS AND PATENTS PENDING. UNAUTHORIZED REPRODUCTION AND/OR DISTRIBUTION OF THIS DRAWING IS SPECIFICALLY PROHIBITED.

GLICK BOND

CARSON CITY
NEVADA 89706

CAD CB6210-1

APPROVALS

DATE

TITLE

NUTPLATE, SEALED, STRAIGHT SLEEVE

ANGLES ±1°

DRAWN DAC

27JAN98

SIZE

CAGE CODE

DWG. NO.

REV.

.XX ±.03

CHECKED DAC

27JAN98

A

66530

CB6210

1

.XXX ±.010

RELEASED CGH

30JAN98

.XXXX ±.001

REVISED DAC

27JAN98

SCALE 1/1

27JAN98

SHEET 1 OF 2

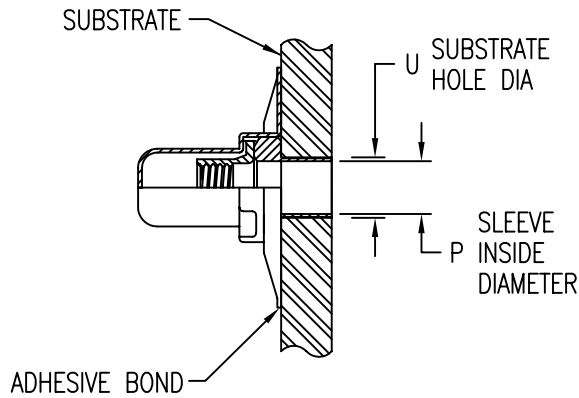

TABLE 2 INSTALLATION HOLE SIZE

THD SIZE CODE	P MIN	U	
		MIN	MAX
3	.225	.250	.255
4	.287	.313	.318
5	.345	.375	.380

TABLE 3 SLEEVE LENGTH

SLEEVE CODE	SLEEVE LENGTH L ±.010
1	.031
2	.062
3	.093
4	.125
5	.156
6	.187
7	.218
8	.250
9	.281
10	.312
11	.343
12	.375
13	.406
14	.437
15	.468
16	.500
17	.531
18	.562
19	.593
20	.625
21	.656
22	.687
23	.718
24	.750
25	.781
26	.812
27	.843
28	.875
29	.906
30	.937
31	.968
32	1.000

MATERIAL AND FINISH DATA

CODE	NUT MATERIAL	SPEC	FINISH	SPEC
-	A-286 CRES	AMS 5525, 5726, 5731, 5732, 5737	PASSIVATE	QQ-P-35

DRI-FILM LUBE ON NUT PER MIL-L-46010, TYPE 1.

CODE	DOME MATERIAL	SPEC	FINISH	SPEC
CR	A-286 CRES	AMS 5525, 5726, 5731, 5732, 5737	PASSIVATE	QQ-P-35

CODE	WASHER MATERIAL	SPEC	FINISH	SPEC
CR	A-286 CRES	AMS 5726, 5731, 5732, 5737	PASSIVATE	QQ-P-35

OPTIONAL PRIMER

CODE	BASEPLATE PRIMER	SPEC
P	EPOXY PRIMER	MIL-P-85582

OPTIONAL TOPCOAT

CODE	SPEC
F	MIL-C-27725 TYP 2 CL B YELLOW

EXAMPLE PART NUMBER

CB6210 CR 4 - 4 P 4 F

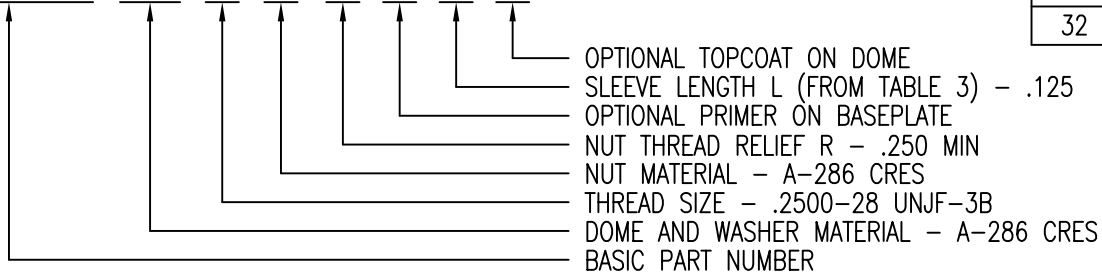

OPTIONAL TOPCOAT ON DOME
 SLEEVE LENGTH L (FROM TABLE 3) - .125
 OPTIONAL PRIMER ON BASEPLATE
 NUT THREAD RELIEF R - .250 MIN
 NUT MATERIAL - A-286 CRES
 THREAD SIZE - .2500-28 UNJF-3B
 DOME AND WASHER MATERIAL - A-286 CRES
 BASIC PART NUMBER

UNLESS OTHERWISE SPECIFIED, ALL DIMENSIONS ARE IN INCHES AND TOLERANCES ARE AS SHOWN BELOW. DIMENSIONAL TOLERANCES AND SYMBOLS PER ANSI Y14.5M-1982.

PROPRIETARY PARTS SHOWN IN THIS DRAWING ARE THE SUBJECT OF ISSUED UNITED STATES AND FOREIGN PATENTS AND PATENTS PENDING. UNAUTHORIZED REPRODUCTION AND/OR DISTRIBUTION OF THIS DRAWING IS SPECIFICALLY PROHIBITED.



CARSON CITY
 NEVADA 89706

CAD CB6210-2

APPROVALS		DATE
DRAWN	DAC	27JAN98
CHECKED	DAC	27JAN98
RELEASED	CGH	30JAN98
REVISED	DAC	27JAN98

TITLE
 NUTPLATE, SEALED, STRAIGHT SLEEVE

SIZE	CAGE CODE	DWG. NO.	REV.
A	66530	CB6210	1
SCALE	1/1	27JAN98	SHEET 2 OF 2