

NUTPLATE MEETS THE STRENGTH REQUIREMENTS OF NASM25027.

OPTIONAL PRIMER THIS SURFACE.

NUTPLATE ATTACHED BY ADHESIVE APPLIED TO THIS SURFACE.

DISPOSABLE ELASTIC FIXTURES HOLD NUTPLATE WHILE ADHESIVE CURES.

NOTE: ALL DIMENSIONS BEFORE PAINT.

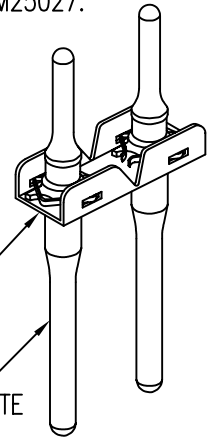

PART NUMBER	THREAD T	B MAX	D MIN	E MAX	H MAX	R MIN
CB6012 () 08 () 1 () ()	.1640-32 UNJC-3B	.454	.224	.187	.250	.070
CB6012 () 3 () 1 () ()					.250	.070
CB6012 () 3 () 2 () ()					.312	.125
CB6012 () 3 () 3 () ()					.375	.188
CB6012 () 3 () 4 () ()					.438	.250
CB6012 () 3 () 5 () ()					.500	.313
CB6012 () 3 () 6 () ()	.1900-32 UNJF-3B	.454	.250	.187	.562	.375
CB6012 () 4 () 1 () ()					.295	.070
CB6012 () 4 () 2 () ()					.357	.125
CB6012 () 4 () 3 () ()					.419	.188
CB6012 () 4 () 4 () ()					.481	.250
CB6012 () 4 () 5 () ()					.543	.313
CB6012 () 4 () 6 () ()	.2500-28 UNJF-3B	.554	.312	.218	.605	.375
CB6012 () 5 () 1 () ()					.344	.070
CB6012 () 5 () 2 () ()					.400	.125
CB6012 () 5 () 3 () ()					.461	.188
CB6012 () 5 () 4 () ()					.524	.250
CB6012 () 5 () 5 () ()					.586	.313
CB6012 () 5 () 6 () ()	.3125-24 UNJF-3B	.650	.375	.276	.649	.375

EXAMPLE PART NUMBER

CB6012 CR 3 - 1 P 6

- ↑ NUT SPACING P IN EIGHTHS OF AN INCH - .750
- ↑ OPTIONAL PRIMER COATING ON BASEPLATE
- ↑ THREAD RELIEF R - .070 MIN
- ↑ NUT MATERIAL - A-286 CRES, DRI-FILM LUBE
- ↑ THREAD T SIZE - .1900-32 UNJF-3B
- ↑ BASEPLATE MATERIAL - A-286 CRES
- ↑ BASIC PART NUMBER

UNLESS OTHERWISE SPECIFIED, ALL DIMENSIONS ARE IN INCHES AND TOLERANCES ARE AS SHOWN BELOW. DIMENSIONAL TOLERANCES AND SYMBOLS PER ANSI Y14.5M-1982.

PROPRIETARY PARTS SHOWN IN THIS DRAWING ARE THE SUBJECT OF ISSUED UNITED STATES AND FOREIGN PATENTS AND PATENTS PENDING. UNAUTHORIZED REPRODUCTION AND/OR DISTRIBUTION OF THIS DRAWING IS SPECIFICALLY PROHIBITED.

GLICK BOND

CARSON CITY
NEVADA 89706

CAD CB6012-1

APPROVALS	DATE
DRAWN BPEREZ	20JUN03
CHECKED DOC	20JUN03
RELEASED CGH	20JUN03
REVISED BPEREZ	20JUN03

TITLE			
NUTPLATE, DOUBLE NUT, BONDED			
SIZE	CAGE CODE	DWG. NO.	REV.
A	66530	CB6012	8
SCALE	2/1	20JUN03	SHEET 1 OF 4

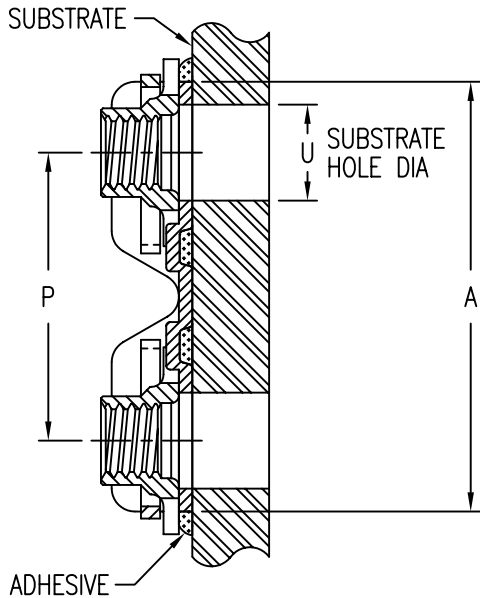

INSTALLATION HOLE SIZE AND REPLACEMENT COMPONENTS

THREAD SIZE CODE	U MAX	NUT PART NO. *	CLIP PART NO.
08	.224	CB6001()08-1	CB6002-3
3	.250	CB6001()3-()	
4	.312	CB6001()4-()	CB6002-4
5	.375	CB6001()5-()	CB6002-5

* FIRST () DESIGNATES NUT MATERIAL CODE.

CR = A-286 CRES, PASSIVATE, DRI-FILM LUBE.
 CRC = A-286 CRES, CAD PLATE, DRI-FILM LUBE.
 CRS = A-286 CRES, SILVER PLATE.

* SECOND () DESIGNATES NUTPLATE THREAD RELIEF (NUT C'BORE) CODE.

BASEPLATE MATERIAL AND FINISH DATA

CODE	MATERIAL	SPEC.	FINISH	SPEC.
A	ALUMINUM	QQ-A-250	NONE	
AA	ALUMINUM	QQ-A-250	ANODIZE	MIL-A-8625, TYPE 1
CR	A-286 CRES	AMS 5525	PASSIVATE	QQ-P-35

OPTIONAL BASEPLATE PRIMER

CODE	COATING MATERIAL	SPEC.
-	NONE	
P	EPOXY PRIMER	MIL-P-85582

NUT MATERIAL AND FINISH DATA (SEE CB6001)

CODE	MATERIAL	FINISH	SPEC.	DRI-FILM LUBE
-	A-286 CRES	PASSIVATE	QQ-P-35	MIL-L-46010 TY 1
CRC	A-286 CRES	CAD PLATE	QQ-P-416	MIL-L-46010 TY 1
CRS	A-286 CRES	SILVER PLATE	AMS 2410	NONE

CLIP MATERIAL AND FINISH: SEE CB6002

NUT SPACING CODE (IN EIGHTHS OF AN INCH)	P	A MAX FOR THREAD SIZES		
		08 AND 3	4	5
5	.625	1.010	1.070	-
6	.750	1.135	1.195	-
7	.875	1.260	1.320	1.437
8	1.000	1.385	1.445	1.562
9	1.125	1.510	1.570	1.687
10	1.250	1.635	1.695	1.812

NOTES: (PART NUMBER CHANGE 18NOV96, NUTPLATE DESIGN SAME)

1. CB6012()2()1 PART NUMBER IS INACTIVE FOR NEW DESIGN. USE CB6012()08()1.
2. NUT MATERIAL AND FINISH DESIGNATION (CR) IS INACTIVE FOR NEW DESIGN. NUT MATERIAL AND FINISH CODE (-) HAS REPLACED (CR).

UNLESS OTHERWISE SPECIFIED, ALL DIMENSIONS ARE IN INCHES AND TOLERANCES ARE AS SHOWN BELOW. DIMENSIONAL TOLERANCES AND SYMBOLS PER ANSI Y14.5M-1982.

PROPRIETARY PARTS SHOWN IN THIS DRAWING ARE THE SUBJECT OF ISSUED UNITED STATES AND FOREIGN PATENTS AND PATENTS PENDING. UNAUTHORIZED REPRODUCTION AND/OR DISTRIBUTION OF THIS DRAWING IS SPECIFICALLY PROHIBITED.



CARSON CITY
NEVADA 89706

CAD CB6012-2		APPROVALS		DATE	TITLE			
ANGLES ±1°		DRAWN BPerez		20JUN03	NUTPLATE, DOUBLE NUT, BONDED			
.XX	±.03	CHECKED DOC/mtm		20JUN03	SIZE	CAGE CODE	DWG. NO.	REV.
.XXX	±.010	RELEASED CGH		20JUN03	A	66530	CB6012	8
.XXXX	±.001	REVISED BPerez		20JUN03	SCALE	2/1 20JUN03		SHEET 2 OF 4

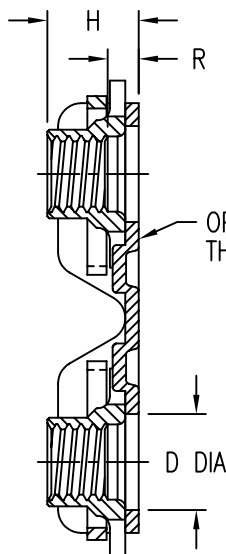
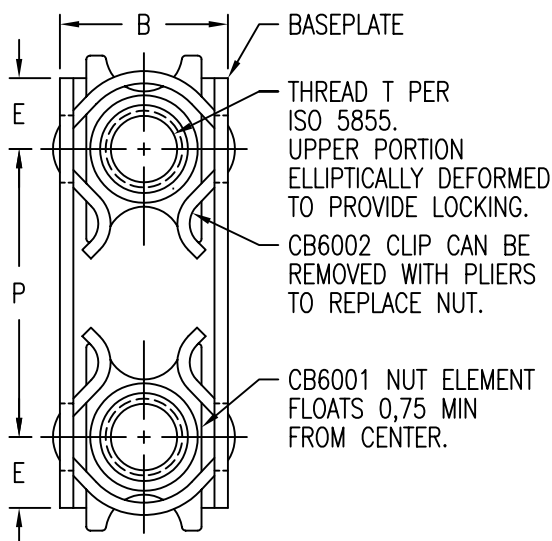

NUTPLATE MEETS THE STRENGTH REQUIREMENTS OF ISO 5858.

NUTPLATE ATTACHED BY ADHESIVE APPLIED TO THIS SURFACE.
DISPOSABLE ELASTIC FIXTURES HOLD NUTPLATE WHILE ADHESIVE CURES.

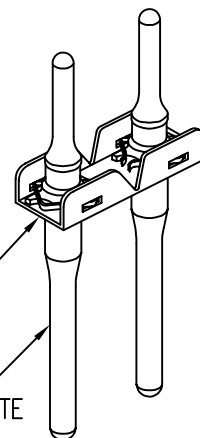

THREAD AND DIMENSION DATA (ALL DIMENSIONS BEFORE PAINT)

PART NUMBER	THREAD T	B MAX	D MIN	E MAX	H MAX	R MIN
CB6012 () 5M () 1 () ()	MJ5 X 0,8 4H6H	11,6	6,35	4,8	6,2	1,6
CB6012 () 5M () 4 () ()					8,0	4,0
CB6012 () 5M () 6 () ()					10,0	6,0
CB6012 () 5M () 8 () ()					12,0	8,0
CB6012 () 5M () 10 () ()					14,0	10,0
CB6012 () 6M () 1 () ()	MJ6 X 1,0 4H5H	14,1	7,90	5,6	7,1	1,6
CB6012 () 6M () 4 () ()					9,0	4,0
CB6012 () 6M () 6 () ()					11,0	6,0
CB6012 () 6M () 8 () ()					13,0	8,0
CB6012 () 6M () 10 () ()					15,0	10,0
CB6012 () 8M () 1 () ()	MJ8 X 1,0 4H5H	16,6	9,50	7,1	8,2	1,6
CB6012 () 8M () 4 () ()					11,0	4,0
CB6012 () 8M () 6 () ()					13,0	6,0
CB6012 () 8M () 8 () ()					15,0	8,0
CB6012 () 8M () 10 () ()					17,0	10,0

EXAMPLE PART NUMBER

CB6012 CR 5M 1 P 19

NUT SPACING P IN MILLIMETERS - 19,0
 OPTIONAL PRIMER COATING ON BASEPLATE
 THREAD RELIEF R - 1,6 MIN
 NUT MATERIAL - A-286 CRES, DRI-FILM LUBE
 THREAD T SIZE - MJ5 X 0,8 4H6H
 BASEPLATE MATERIAL - A-286 CRES
 BASIC PART NUMBER

UNLESS OTHERWISE SPECIFIED, ALL DIMENSIONS ARE IN MILLIMETERS AND TOLERANCES ARE AS SHOWN BELOW. DIMENSIONAL TOLERANCES AND SYMBOLS PER ANSI Y14.5M-1982.

PROPRIETARY PARTS SHOWN IN THIS DRAWING ARE THE SUBJECT OF ISSUED UNITED STATES AND FOREIGN PATENTS AND PATENTS PENDING. UNAUTHORIZED REPRODUCTION AND/OR DISTRIBUTION OF THIS DRAWING IS SPECIFICALLY PROHIBITED.

GLICK BOND

CARSON CITY
NEVADA 89706

CAD CB6012-3
METRIC DIMENSIONS

APPROVALS	DATE
DRAWN BPEREZ	20JUN03
CHECKED DOC	20JUN03
RELEASED CGH	20JUN03
REVISED BPEREZ	20JUN03

TITLE
NUTPLATE, DOUBLE NUT, BONDED

ANGLES	±1°
.X	±0,8
.XX	±0,25

SIZE	CAGE CODE	DWG. NO.	REV.
A	66530	CB6012 (METRIC)	8
SCALE	2/1	20JUN03	SHEET 3 OF 4

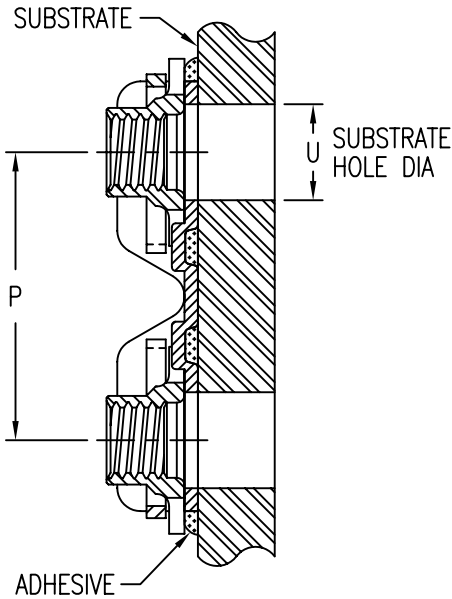

INSTALLATION HOLE SIZE AND REPLACEMENT COMPONENTS

THREAD SIZE CODE	U MAX	NUT PART NO. *	CLIP PART NO.
5M	6,35	CB6001()5M()	CB6002-5M
6M	7,90	CB6001()6M()	CB6002-6M
8M	9,50	CB6001()8M()	CB6002-8M

* FIRST () DESIGNATES NUT MATERIAL CODE.

- CR = A-286 CRES, PASSIVATE, DRI-FILM LUBE.
- CRC = A-286 CRES, CAD PLATE, DRI-FILM LUBE.
- CRS = A-286 CRES, SILVER PLATE.

* SECOND () DESIGNATES NUTPLATE THREAD RELIEF (NUT C'BORE) CODE.

BASEPLATE MATERIAL AND FINISH DATA

CODE	MATERIAL	SPEC.	FINISH	SPEC.
A	ALUMINUM	QQ-A-250	NONE	
AA	ALUMINUM	QQ-A-250	ANODIZE	MIL-A-8625, TYPE 1
CR	A-286 CRES	AMS 5525	PASSIVATE	QQ-P-35

OPTIONAL PRIMER COATING

CODE	COATING MATERIAL	SPEC.
-	NONE	
P	EPOXY PRIMER	MIL-P-85582

OPTIONAL PRIMER COATING ON BASEPLATE: EPOXY PRIMER PER MIL-P-85582.

NUT MATERIAL AND FINISH DATA (SEE CB6001)

CODE	MATERIAL	FINISH	SPEC.	DRI-FILM LUBE
NONE	A-286 CRES	PASSIVATE	QQ-P-35	MIL-L-46010 TY 1
CRC	A-286 CRES	CAD PLATE	QQ-P-416	MIL-L-46010 TY 1
CRS	A-286 CRES	SILVER PLATE	AMS 2410	NONE

RECOMMENDED MINIMUM NUT SPACING

THREAD SIZE CODE	MINIMUM P
5M	14,0
6M	16,0
8M	20,0

CLIP MATERIAL AND FINISH: SEE CB6002

STRENGTH REQUIREMENT: PER ISO 5858.

UNLESS OTHERWISE SPECIFIED, ALL DIMENSIONS ARE IN MILLIMETERS AND TOLERANCES ARE AS SHOWN BELOW. DIMENSIONAL TOLERANCES AND SYMBOLS PER ANSI Y14.5M-1982.

PROPRIETARY PARTS SHOWN IN THIS DRAWING ARE THE SUBJECT OF ISSUED UNITED STATES AND FOREIGN PATENTS AND PATENTS PENDING. UNAUTHORIZED REPRODUCTION AND/OR DISTRIBUTION OF THIS DRAWING IS SPECIFICALLY PROHIBITED.

GLICK BOND

CARSON CITY
NEVADA 89706

CAD CB6012-4
METRIC DIMENSIONS

APPROVALS	DATE
DRAWN BPEREZ	20JUN03
CHECKED CGH	20JUN03
RELEASED CGH	20JUN03
REVISED BPEREZ	20JUN03

TITLE
NUTPLATE, DOUBLE NUT, BONDED

ANGLES	±1°
.X	±0,8
.XX	±0,25

SIZE	CAGE CODE	DWG. NO.	REV.
A	66530	CB6012 (METRIC)	8
SCALE	2/1	20JUN03	SHEET 4 OF 4