

NUTPLATE MEETS THE STRENGTH AND REUSABILITY REQUIREMENTS OF NASM25027.

THREAD AND DIMENSION DATA (ALL DIMENSIONS BEFORE PAINT)

PART NUMBER	THREAD SIZE	A MAX	B MAX	D MIN	H MAX	R MIN	WEIGHT * (A-286 CRES) LB/100	WEIGHT * (ALUMINUM) LB/100
CB6009()08()1	.1640-32 UNJC-3B	.745	.454	.224	.250	.070	.54	.33
CB6009()3()1	.1900-32 UNJF-3B	.745	.454	.250	.250	.070	.57	.36
CB6009()3()2					.312	.125	.62	.41
CB6009()3()3					.375	.188	.67	.46
CB6009()3()4					.438	.250	.74	.53
CB6009()3()5					.500	.313	.78	.57
CB6009()3()6					.562	.375	.83	.62
CB6009()3()7					.625	.438	.88	.67
CB6009()3()8					.687	.500	.93	.72
CB6009()4()1	.2500-28 UNJF-3B	.948	.554	.312	.295	.070	1.04	.69
CB6009()4()2					.357	.125	1.09	.74
CB6009()4()3					.419	.188	1.13	.78
CB6009()4()4					.481	.250	1.22	.87
CB6009()4()5					.543	.313	1.31	.96
CB6009()4()6					.605	.375	1.41	1.05
CB6009()4()7					.668	.438	1.49	1.13
CB6009()4()8					.730	.500	1.57	1.21
CB6009()5()1	.3125-24 UNJF-3B	1.042	.650	.375	.344	.070	1.52	1.02
CB6009()5()2					.400	.125	1.58	1.08
CB6009()5()3					.461	.188	1.69	1.19
CB6009()5()4					.524	.250	1.81	1.31
CB6009()5()5					.586	.313	1.92	1.42
CB6009()5()6					.649	.375	2.03	1.53
CB6009()5()7					.711	.438	2.13	1.63
CB6009()5()8					.774	.500	2.23	1.73
CB6009()6()1	.3750-24 UNJF-3B	1.182	.750	.437	.380	.070	2.40	1.58
CB6009()6()2					.430	.125	2.52	1.70
CB6009()7()1	.4375-20 UNJF-3B	1.307	.840	.500	.500	.070	3.80	2.80
CB6009()8()1	.5000-20 UNJF-3B	1.432	.900	.562	.580	.070	4.35	3.20

* APPROXIMATE WEIGHT WITHOUT INSTALLATION FIXTURE (BASEPLATE MATERIAL IN PARENTHESIS)

UNLESS OTHERWISE SPECIFIED, ALL DIMENSIONS ARE IN INCHES AND TOLERANCES ARE AS SHOWN BELOW. DIMENSIONAL TOLERANCES AND SYMBOLS PER ANSI Y14.5M-1982.

THE PARTS SHOWN IN THIS DRAWING ARE PROPRIETARY AND MAY BE THE SUBJECT OF ISSUED UNITED STATES AND FOREIGN PATENTS AND PATENTS PENDING. UNAUTHORIZED REPRODUCTION AND/OR DISTRIBUTION OF THIS DRAWING IS SPECIFICALLY PROHIBITED.



2151 LOCKHEED WAY
CARSON CITY, NEVADA 89706

APPROVALS		DATE		TITLE			
ANGLES	±1°	DRAWN	GTP	NUTPLATE, TWO LUG, ADHESIVE BONDED			
.XX	±.03	CHECKED	<i>DO Carter</i>	SIZE	CAGE CODE	DWG. NO.	REV.
.XXX	±.010	RELEASED	JLH	A	66530	CB6009	24
.XXXX	±.001	REVISED	GTP	SCALE: 2:1		18FEB21	SHEET 1 OF 4

INSTALLATION HOLE SIZE

SIZE	ØU
08	.164 - .224
3	.190 - .250
4	.250 - .312
5	.312 - .375
6	.375 - .437
7	.437 - .500
8	.500 - .562

BF SUFFIX OVERSIZE HOLE

CODE	ØU
08	.224 - .286
3	.250 - .312
4	.312 - .375
5	.375 - .437

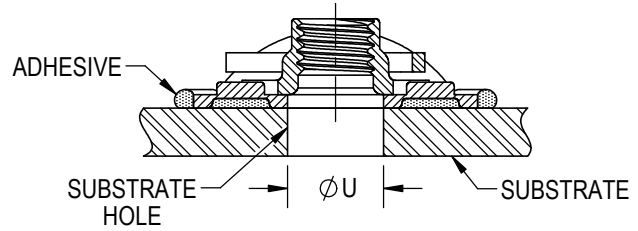

BASEPLATE MATERIAL AND FINISH DATA

CODE	MATERIAL	SPEC.	FINISH	SPEC.
A	ALUMINUM	AMS-QQ-A-250	NONE	
AA	ALUMINUM	AMS-QQ-A-250	ANODIZE	MIL-A-8625 TYPE I, CLASS 1, NO SEAL
CR	A-286 CRES	AMS 5525	PASSIVATE	AMS 2700 METHOD 1, TYPE 8

BL SUFFIX FIXTURE LENGTH

SIZE	X REF (STANDARD)	Y REF (BL SUFFIX)
3	1.7	4.7
4	2.0	4.9
6	2.0	4.9

NUT MATERIAL AND FINISH DATA (SEE CB6001)

CODE	MATERIAL	FINISH	SPEC.	DRI-FILM LUBE	REUSABILITY TEST BOLT
-	A-286 CRES	PASSIVATE	AMS 2700		CRES
CRC	A-286 CRES	CADMIUM PLATE	AMS-QQ-P-416	AS5272	CRES
CRS	A-286 CRES	SILVER PLATE	AMS 2410	NONE	CRES
CRT	A-286 CRES	COPPER PLATE	AMS 2418	AS5272	TITANIUM

RETAINING CLIP MATERIAL AND FINISH DATA (SEE CB6002)

MATERIAL	SPEC.	PASSIVATE
XM-28 (UNS S24100) STAINLESS STEEL SPRING WIRE	ASTM A313/A313M	AMS 2700

PART NUMBER SUFFIXES (BF AND BL SUFFIXES CANNOT BE USED TOGETHER)

CODE	DESCRIPTION
NL	NON-LOCKING NUT ELEMENT
R	THREAD LOCK MEETS NASM25027 REUSE REQUIREMENTS FOR 50 REUSE CYCLES MANUFACTURER'S OPTION: COPPER PLATE PER AMS 2418
BF	FIXTURE FOR OVERSIZE INSTALLATION HOLE (SIZES 08 - 5 ONLY)
BL	EXTRA LONG FIXTURE (SIZE 3, 4, AND 6 ONLY)

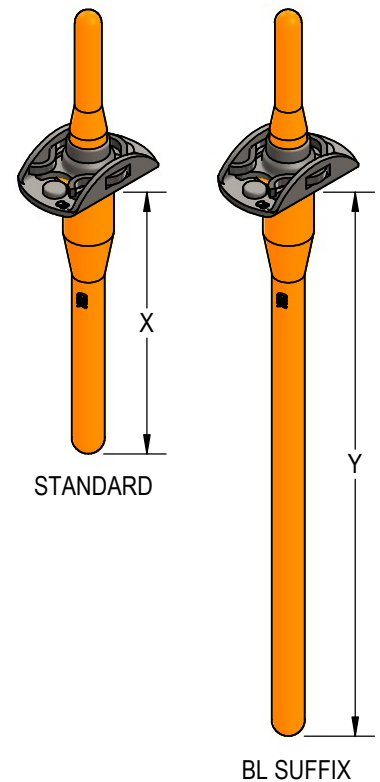

NOTES: (PART NUMBER CHANGED 24OCT96, NUTPLATE DESIGN SAME)

- PART NUMBER CB6009()2()1 IS INACTIVE FOR NEW DESIGN, USE CB6009()08()1.
- NUT MATERIAL AND FINISH CODE "CR" IS INACTIVE FOR NEW DESIGN, USE CODE "-".

EXAMPLE PART NUMBER

CB6009 CR 3 - 1 P

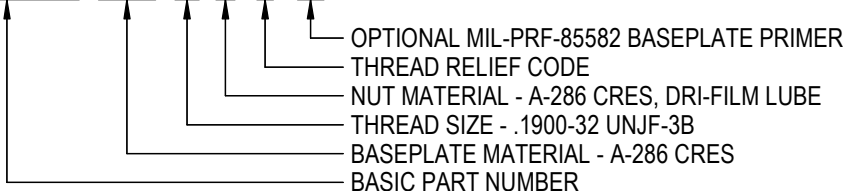

UNLESS OTHERWISE SPECIFIED, ALL DIMENSIONS ARE IN INCHES AND TOLERANCES ARE AS SHOWN BELOW. DIMENSIONAL TOLERANCES AND SYMBOLS PER ANSI Y14.5M-1982.		CLICK BOND		2151 LOCKHEED WAY CARSON CITY, NEVADA 89706	
ANGLES ±1°		TITLE		NUTPLATE, TWO LUG, ADHESIVE BONDED	
.XX ±.03	SIZE	CAGE CODE	DWG. NO.	REV.	
.XXX ±.010	A	66530	CB6009	24	
.XXXX ±.001	SCALE: 2:1		18FEB21	SHEET 2 OF 4	

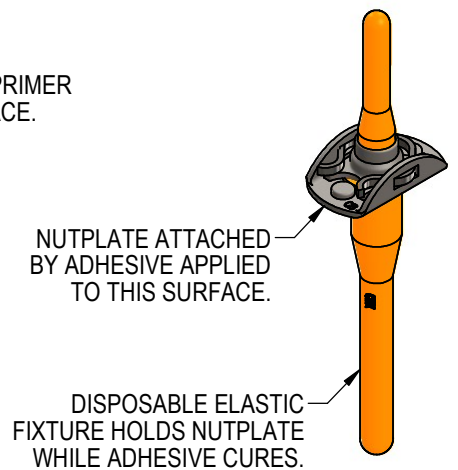
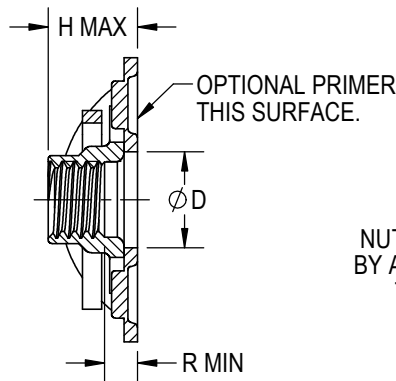
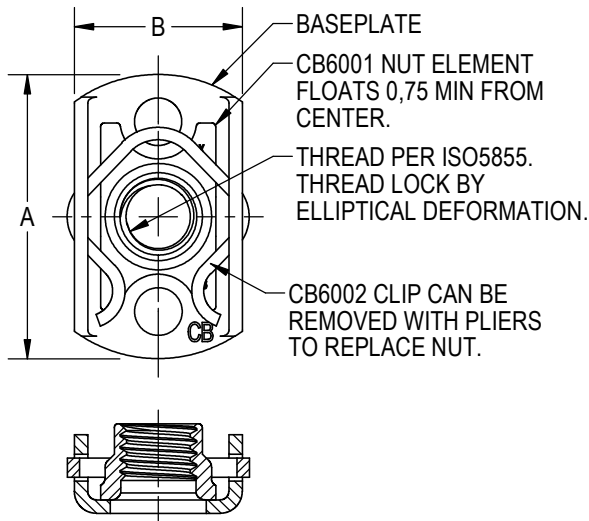

NUTPLATE MEETS THE STRENGTH AND REUSABILITY REQUIREMENTS OF ISO5858 (900 MPa).

THREAD AND DIMENSION DATA (ALL DIMENSIONS BEFORE PAINT)

PART NUMBER	THREAD SIZE	A MAX	B MAX	D MIN	H MAX	R MIN	WEIGHT * (A-286 CRES) grams	WEIGHT * (ALUMINUM) grams
CB6009()4M()1	MJ4 X 0,7 4H6H	19,0	11,6	5,50	5,2	1,6	2,5	1,6
CB6009()5M()1	MJ5 X 0,8 4H6H	19,0	11,6	6,35	6,2	1,6	2,7	1,7
CB6009()5M()4					8,0	4,0	3,0	2,0
CB6009()5M()6					10,0	6,0	3,3	2,3
CB6009()5M()8					12,0	8,0	3,6	2,6
CB6009()5M()10					14,0	10,0	3,9	2,9
CB6009()5M()12					16,0	12,0	4,2	3,2
CB6009()6M()1	MJ6 X 1,0 4H5H	24,1	14,1	7,50	7,1	1,6	4,8	3,1
CB6009()6M()4					9,0	4,0	5,3	3,7
CB6009()6M()6					11,0	6,0	5,9	4,2
CB6009()6M()8					13,0	8,0	6,4	4,7
CB6009()6M()10					15,0	10,0	6,9	5,3
CB6009()6M()12					17,0	12,0	7,4	5,8
CB6009()8M()1	MJ8 X 1,0 4H5H	26,5	16,6	9,50	8,2	1,6	7,1	4,7
CB6009()8M()4					11,0	4,0	7,9	5,6
CB6009()8M()6					13,0	6,0	8,6	6,2
CB6009()8M()8					15,0	8,0	9,2	6,9
CB6009()8M()10					17,0	10,0	9,9	7,5
CB6009()8M()12					19,0	12,0	10,6	8,2
CB6009()10M()1	MJ10 X 1,25 4H5H	30,1	19,1	11,10	9,9	1,6	11,4	7,5

* APPROXIMATE WEIGHT WITHOUT INSTALLATION FIXTURE (BASEPLATE MATERIAL IN PARENTHESIS)

UNLESS OTHERWISE SPECIFIED, ALL DIMENSIONS ARE IN MILLIMETERS AND TOLERANCES ARE AS SHOWN BELOW. DIMENSIONAL TOLERANCES AND SYMBOLS PER ANSI Y14.5M-1982.		CLICK BOND		2151 LOCKHEED WAY CARSON CITY, NEVADA 89706	
METRIC DIMENSIONS				TITLE NUTPLATE, TWO LUG, ADHESIVE BONDED	
ANGLES	±1°	SIZE	CAGE CODE	DWG. NO.	REV.
X	±0,8	A	66530	CB6009 (METRIC)	24
.XX	±0,25	SCALE: 2:1		18FEB21	SHEET 3 OF 4

INSTALLATION HOLE SIZE

SIZE	ØU
4M	4,00 - 5,50
5M	5,00 - 6,35
6M	6,00 - 7,50
8M	8,00 - 9,50
10M	10,00 - 11,10

BF SUFFIX OVERSIZE HOLE

CODE	ØU
4M	5,50 - 7,00
5M	6,35 - 7,85
6M	7,50 - 9,00
8M	9,50 - 11,00

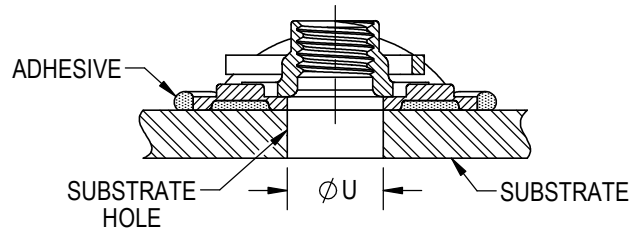

BASEPLATE MATERIAL AND FINISH DATA

CODE	MATERIAL	SPEC.	FINISH	SPEC.
A	ALUMINUM	AMS-QQ-A-250	NONE	
AA	ALUMINUM	AMS-QQ-A-250	ANODIZE	MIL-A-8625 TYPE I, CLASS 1, NO SEAL
CR	A-286 CRES	AMS 5525	PASSIVATE	AMS 2700 METHOD 1, TYPE 8

BL SUFFIX FIXTURE LENGTH

SIZE	X REF (STANDARD)	Y REF (BL SUFFIX)
5M	43	120
6M	51	125
10M	51	125

NUT MATERIAL AND FINISH DATA (SEE CB6001)

CODE	MATERIAL	FINISH	SPEC.	DRI-FILM LUBE	REUSABILITY TEST BOLT
NONE	A-286 CRES	PASSIVATE	AMS 2700	AS5272	CRES
CRC	A-286 CRES	CADMIUM PLATE	AMS-QQ-P-416		CRES
CRS	A-286 CRES	SILVER PLATE	AMS 2410	NONE	CRES
CRT	A-286 CRES	COPPER PLATE	AMS 2418	AS5272	TITANIUM

RETAINING CLIP MATERIAL AND FINISH DATA (SEE CB6002)

MATERIAL	SPEC.	PASSIVATE
XM-28 (UNS S24100) STAINLESS STEEL SPRING WIRE	ASTM A313/A313M	AMS 2700

PART NUMBER SUFFIXES (BF AND BL SUFFIXES CANNOT BE USED TOGETHER)

CODE	DESCRIPTION
NL	NON-LOCKING NUT ELEMENT
R	THREAD LOCK MEETS ISO5858 REUSE REQUIREMENTS FOR 50 REUSE CYCLES MANUFACTURER'S OPTION: COPPER PLATE PER AMS 2418
BF	FIXTURE FOR OVERSIZE INSTALLATION HOLE (SIZES 4M - 8M ONLY)
BL	EXTRA LONG FIXTURE (SIZE 5M, 6M, AND 10M ONLY)

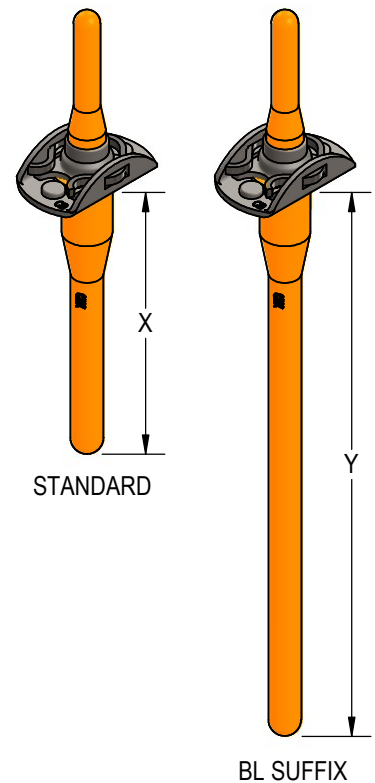

EXAMPLE PART NUMBER

CB6009 CR 5M 1 P

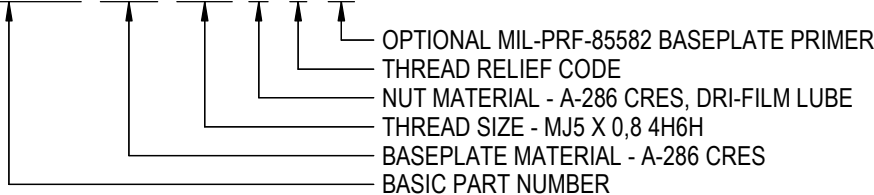

UNLESS OTHERWISE SPECIFIED, ALL DIMENSIONS ARE IN MILLIMETERS AND TOLERANCES ARE AS SHOWN BELOW. DIMENSIONAL TOLERANCES AND SYMBOLS PER ANSI Y14.5M-1982.				2151 LOCKHEED WAY CARSON CITY, NEVADA 89706	
METRIC DIMENSIONS				TITLE NUTPLATE, TWO LUG, ADHESIVE BONDED	
ANGLES	±1°	SIZE	CAGE CODE	DWG. NO.	REV.
X	±0,8	A	66530	CB6009 (METRIC)	24
.XX	±0,25	SCALE: 2:1		18FEB21	SHEET 4 OF 4