

DISPOSABLE PRESSURE SENSITIVE ADHESIVE FIXTURE HOLDS NUTPLATE WHILE ADHESIVE CURES.

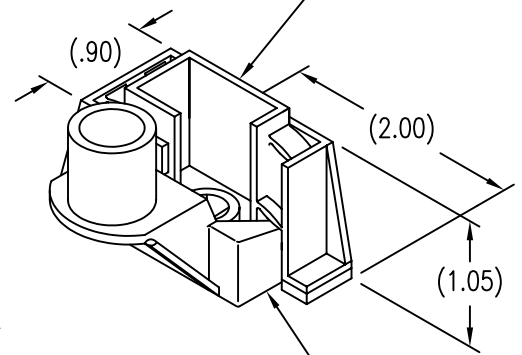

NUTPLATE ATTACHED BY ADHESIVE APPLIED TO THIS SURFACE.

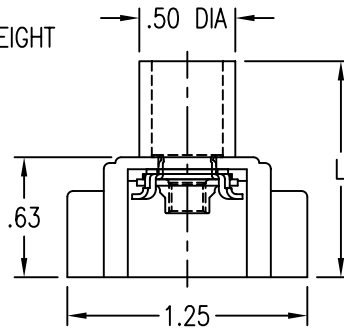

NUT MATERIAL AND FINISH DATA

CODE	NUT MATERIAL	SPEC.	RETAINER MATERIAL	SPEC.	FINISH	SPEC.
CR	A-286 CRES	AMS 5525	A-286 AND 304 OR 305 CRES	AMS 5514, 5525, 5639	PASSIVATE	QQ-P-35

STANDOFF MATERIAL AND FINISH DATA

CODE	STANDOFF MATERIAL	FINISH
V	GLASS/THERMOPLASTIC, 350°F	ABRASIVE CLEAN

THREAD T DATA

CODE	THREAD SIZE	SPEC.
08	.1640-32 UNJC-3B	MIL-S-8879
3	.1900-32 UNJF-3B	

DIMENSION DATA

CODE	L	H	R	WEIGHT (LB/100)
10	.63	.32	.15	
18	1.13	.82	.65	
22	1.38	1.07	.90	
24	1.50	1.19	1.02	
28	1.75	1.44	1.27	
32	2.00	1.69	1.52	
34	2.13	1.82	1.65	

RADIAL FLOAT OF NUT .030 MIN FROM CENTER.
 NUT CAN ENGAGE SCREW FROM MAX MISALIGNED POSITION.
 NUT CAN BE REMOVED FROM RETAINER AND REPLACED.
 THREAD LOCK PER NASM25027.
 DRI-FILM LUBE ON NUT PER MIL-L-46010 TY 1.
 STRENGTH - WILL WITHSTAND 50 LB LOAD APPLIED IN ANY DIRECTION.
 RECOMMENDED FASTENER TIGHTENING TORQUE IS 20-25 INCH-LBS.

EXAMPLE PART NUMBER

CB4014 V 3 CR 18

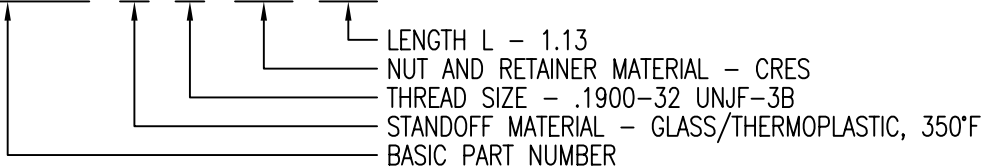

UNLESS OTHERWISE SPECIFIED, ALL DIMENSIONS ARE IN INCHES AND TOLERANCES ARE AS SHOWN BELOW. DIMENSIONAL TOLERANCES AND SYMBOLS PER ANSI Y14.5M-1982.

PROPRIETARY PARTS SHOWN IN THIS DRAWING ARE THE SUBJECT OF ISSUED UNITED STATES AND FOREIGN PATENTS AND PATENTS PENDING. UNAUTHORIZED REPRODUCTION AND/OR DISTRIBUTION OF THIS DRAWING IS SPECIFICALLY PROHIBITED.

GLICK BOND

CARSON CITY
NEVADA 89706

ANGLES	±1°	APPROVALS		DATE
		DRAWN	DAC	1JUL01
.XX	±.03	CHECKED	DAC	1JUL01
.XXX	±.010	RELEASED	CGH	2JUL01
.XXXX	±.001	REVISED	DAC	1JUL01

TITLE			
NUTPLATE, OFFSET STANDOFF, COMPOSITE			
SIZE	CAGE CODE	DWG. NO.	REV.
A	66530	CB4014	2
SCALE	1/1	1JUL01	SHEET 1 OF 1