

NUT MATERIAL AND FINISH DATA

CODE	MATERIAL	SPEC.	FINISH	SPEC.	DRI-FILM LUBE
CR	A-286 CRES	AMS 5525, 5726, 5731, 5732, 5737	PASSIVATE	AMS 2700	AS5272
CRC	A-286 CRES	AMS 5525, 5726, 5731, 5732, 5737	CAD PLATE	AMS-QQ-P-416	AS5272

WASHER MATERIAL AND FINISH DATA

CODE	MATERIAL	SPEC.	FINISH	SPEC.
CR	A-286 CRES	AMS 5525, 5726, 5731, 5732, 5737	PASSIVATE	AMS 2700
ACR	2024 OR 6061 ALUMINUM	AMS-QQ-A-200, AMS-QQ-A-225	ANODIZE	MIL-A-8625 TYPE 1

DOME MATERIAL AND FINISH DATA

CODE	MATERIAL	SPEC.	PASSIVATE
CR	A-286 CRES	AMS 5525	AMS 2700
ACR			

OPTIONAL TOPCOAT

CODE	MATERIAL SPEC.
F	AMS-C-27725 TYPE 2 CLASS B YELLOW

THREAD AND DIMENSION DATA

CODE	THREAD SIZE	D MIN	U DIA
08	.1640-32 UNJC-3B	.204	.164-.204
3	.1900-32 UNJF-3B	.230	.190-.230

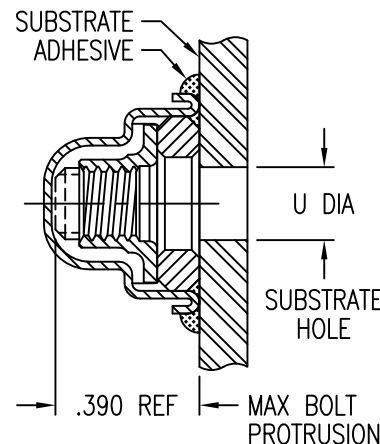

EXAMPLE PART NUMBER

CB2031 CR 3 CR P F

OPTIONAL TOPCOAT ON DOME  
 OPTIONAL MIL-PRF-85582 BASEPLATE PRIMER  
 NUT MATERIAL - A-286 CRES, DRI-FILM LUBE  
 THREAD SIZE - .1900-32 UNJF-3B  
 DOME AND WASHER MATERIAL - A-286 CRES  
 BASIC PART NUMBER

UNLESS OTHERWISE SPECIFIED, ALL DIMENSIONS ARE IN INCHES AND TOLERANCES ARE AS SHOWN BELOW. DIMENSIONAL TOLERANCES AND SYMBOLS PER ANSI Y14.5M-1982.

PROPRIETARY PARTS SHOWN IN THIS DRAWING ARE THE SUBJECT OF ISSUED UNITED STATES AND FOREIGN PATENTS AND PATENTS PENDING. UNAUTHORIZED REPRODUCTION AND/OR DISTRIBUTION OF THIS DRAWING IS SPECIFICALLY PROHIBITED.

**CLICK BOND**

CARSON CITY  
 NEVADA 89706

CAD CB2031-1

APPROVALS DATE

TITLE  
 NUTPLATE, SEALED, LOW PROFILE

ANGLES ±1° DRAWN DAC 13NOV13

.XX ±.03 CHECKED DAC/mtm 13NOV13

SIZE CAGE CODE DWG. NO. REV.  
 A 66530 CB2031 11

.XXX ±.010 RELEASED GBC/mtm 13NOV13

.XXXX ±.001 REVISED DAC 13NOV13

SCALE 2/1 13NOV13 SHEET 1 OF 2

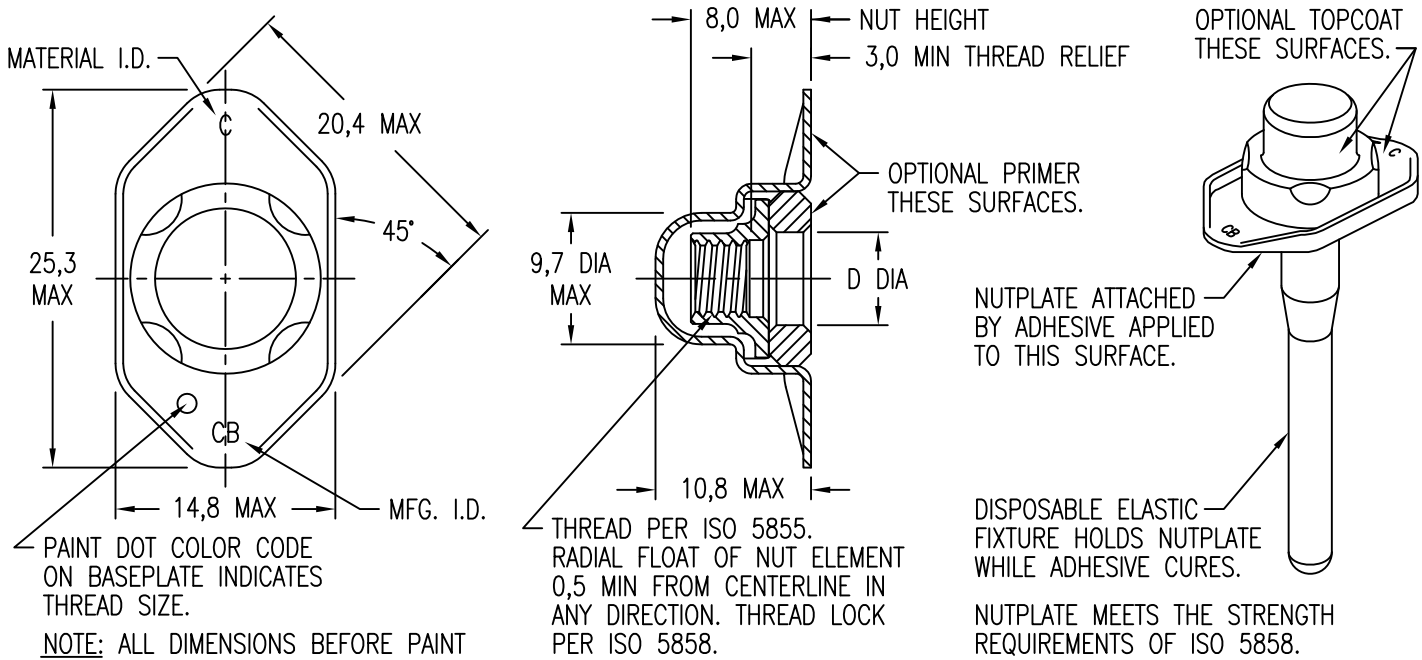

NUT MATERIAL AND FINISH DATA

CODE	MATERIAL	SPEC.	FINISH	SPEC.	DRI-FILM LUBE
CR	A-286 CRES	AMS 5525, 5726, 5731, 5732, 5737	PASSIVATE	AMS 2700	AS5272
CRC	A-286 CRES	AMS 5525, 5726, 5731, 5732, 5737	CAD PLATE	AMS-QQ-P-416	AS5272

WASHER MATERIAL AND FINISH DATA

CODE	MATERIAL	SPEC.	FINISH	SPEC.
CR	A-286 CRES	AMS 5525, 5726, 5731, 5732, 5737	PASSIVATE	AMS 2700
ACR	2024 OR 6061 ALUMINUM	AMS-QQ-A-200, AMS-QQ-A-225	ANODIZE	MIL-A-8625 TYPE 1

DOME MATERIAL AND FINISH DATA

CODE	MATERIAL	SPEC.	PASSIVATE
CR	A-286 CRES	AMS 5525	AMS 2700
ACR			

OPTIONAL TOPCOAT

CODE	MATERIAL SPEC.
F	AMS-C-27725 TYPE 2 CLASS B YELLOW

THREAD AND DIMENSION DATA

CODE	THREAD SIZE	D MIN	U DIA	COLOR CODE
4M	MJ4 X 0,7 4H6H	5,0	4,0-5,0	GREEN
5M	MJ5 X 0,8 4H6H	6,0	5,0-6,0	BLUE

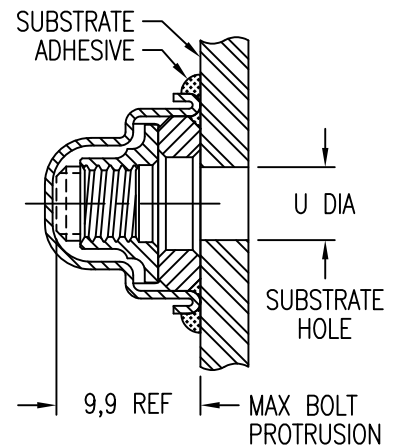

EXAMPLE PART NUMBER

CB2031 CR 5M CR P F

OPTIONAL TOPCOAT ON DOME  
 OPTIONAL MIL-PRF-85582 BASEPLATE PRIMER  
 NUT MATERIAL - A-286 CRES, DRI-FILM LUBE  
 THREAD SIZE - MJ5 X 0,8 4H6H  
 DOME AND WASHER MATERIAL - A-286 CRES  
 BASIC PART NUMBER

UNLESS OTHERWISE SPECIFIED, ALL DIMENSIONS ARE IN MILLIMETERS AND TOLERANCES ARE AS SHOWN BELOW. DIMENSIONAL TOLERANCES AND SYMBOLS PER ANSI Y14.5M-1982.

PROPRIETARY PARTS SHOWN IN THIS DRAWING ARE THE SUBJECT OF ISSUED UNITED STATES AND FOREIGN PATENTS AND PATENTS PENDING. UNAUTHORIZED REPRODUCTION AND/OR DISTRIBUTION OF THIS DRAWING IS SPECIFICALLY PROHIBITED.

**CLICK BOND**

CARSON CITY  
 NEVADA 89706

CAD CB2031-2 METRIC DIMENSIONS	
ANGLES	±1°
.X	±0,8
.XX	±0,25

APPROVALS	DATE
DRAWN DAC	13NOV13
CHECKED DAC/mtm	13NOV13
RELEASED GBC/ati	13NOV13
REVISED DAC	13NOV13

TITLE NUTPLATE, SEALED, LOW PROFILE			
SIZE A	CAGE CODE 66530	DWG. NO. CB2031 (METRIC)	REV. 11
SCALE 2/1	13NOV13	SHEET 2 OF 2	