

NUTPLATE MEETS THE STRENGTH REQUIREMENTS OF MIL-N-25027.

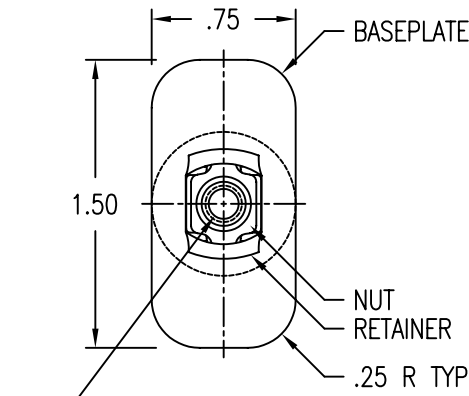

THREAD T PER MIL-S-8879.  
 THREAD LOCK PER MIL-N-25027.  
 DRI-FILM LUBE ON NUT PER MIL-L-46010, TYPE 1.

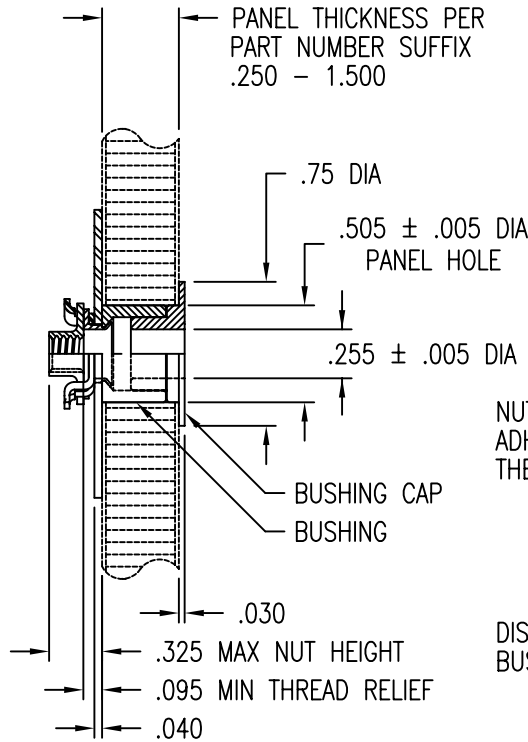

DISPOSABLE ELASTIC FIXTURE HOLDS NUTPLATE ASSEMBLY WHILE ADHESIVE CURES.

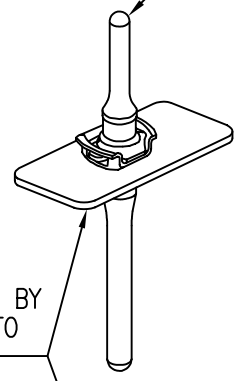

NUTPLATE ATTACHED BY ADHESIVE APPLIED TO THESE SURFACES.

DISPOSABLE PLASTIC BUSHING CAP RETAINER

MATERIAL AND FINISH DATA

CODE	NUT MATERIAL	SPEC.	RETAINER MATERIAL	SPEC.	FINISH	SPEC.
CR	A-286 CRES	AMS 5525	17-7PH, A-286, 304, 305 CRES	AMS 5514, 5525, 5528, 5639	CAD	QQ-P-416
CRA	A-286 CRES	AMS 5525	A-286, 304, 305 CRES	AMS 5514, 5525, 5639	PLATE	TY 2, CL 2

CODE	BASEPLATE MATERIAL	SPEC.	BUSHING MATERIAL	SPEC.	FINISH	SPEC.
AA	6061-T6 ALUMINUM	QQ-A-250	6061-T6 ALUMINUM	QQ-A-200 OR QQ-A-225	ANODIZE	MIL-A-8625 TYPE I
CR	304 CRES	AMS 5513	304 CRES	AMS 5639	PASSIVATE	QQ-P-35
T	6AL-4V TITANIUM	AMS 4911	6AL-4V TITANIUM	AMS 4928, 4965, 4967	NONE	

THREAD T DATA

CODE	THREAD SIZE
08	.1640-32 UNJC-3B
3	.1900-32 UNJC-3B

PRIMER (MANUFACTURER'S OPTION)

EPOXY PRIMER	SPEC.
DEFT 44-GN-11	BMS 10-11 TYPE 1
DEFT 44-GN-24	MIL-P-85582

PRIMER COATING ON BASEPLATE, BUSHING, AND BUSHING CAP.

RADIAL FLOAT OF NUT ELEMENT .030 FROM CL. NUT CAN ENGAGE SCREW FROM MAX MISALIGNED POSITION.

NUT CAN BE REMOVED FROM RETAINER AND REPLACED.

EXAMPLE PART NUMBER

CB2023 AA 3 CRA 400

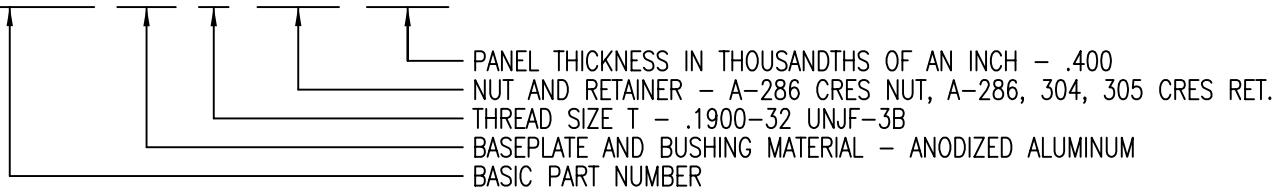

UNLESS OTHERWISE SPECIFIED, ALL DIMENSIONS ARE IN INCHES AND TOLERANCES ARE AS SHOWN BELOW. DIMENSIONAL TOLERANCES AND SYMBOLS PER ANSI Y14.5M-1982.

PROPRIETARY PARTS SHOWN IN THIS DRAWING ARE THE SUBJECT OF ISSUED UNITED STATES AND FOREIGN PATENTS AND PATENTS PENDING. UNAUTHORIZED REPRODUCTION AND/OR DISTRIBUTION OF THIS DRAWING IS SPECIFICALLY PROHIBITED.

**GLICK BOND**

CARSON CITY NEVADA 89706

APPROVALS		DATE	TITLE				
ANGLES	±1°	DRAWN DAC	130CT98	NUTPLATE, SPACER INSERT, FLOATING			
.XX	±.03	CHECKED DAC	130CT98	SIZE	CAGE CODE	DWG. NO.	REV.
.XXX	±.010	RELEASED CGH	130CT98	A	66530	CB2023	1
.XXXX	±.001	REVISED DAC	130CT98	SCALE	1/1	130CT98	SHEET 1 OF 1