

THREAD AND DIMENSION DATA (ALL DIMENSIONS BEFORE PAINT)

PART NUMBER	THREAD T	A MAX	B MAX	D MIN	H MAX	R MIN	U DIA	WEIGHT * LB/100	AXIAL TENSILE STRENGTH LBS MIN
CN609CR08	.164-32 UNC-2B	.745	.454	.224	.250	.070	.164-.224	.54	1720
CN609CR3	.190-32 UNF-2B	.745	.454	.250	.250	.070	.190-.250	.57	2460
CN609CR324	.190-24 UNC-2B	.745	.454	.250	.250	.070	.190-.250	.57	2010
CN609CR4	.250-28 UNF-2B	.948	.554	.312	.295	.070	.250-.312	1.04	4580
CN609CR420	.250-20 UNC-2B	.948	.554	.312	.295	.070	.250-.312	1.04	3760
CN609CR5	.312-24 UNF-2B	1.042	.650	.375	.344	.070	.313-.375	1.52	7390
CN609CR518	.312-18 UNC-2B	1.042	.650	.375	.344	.070	.313-.375	1.52	6360

\* REFERENCE WEIGHT WITHOUT INSTALLATION FIXTURE.

BASEPLATE MATERIAL AND FINISH DATA

CODE	MATERIAL	FINISH
CR	A-286 CRES	PASSIVATE

OPTIONAL BASEPLATE PRIMER

CODE	BASEPLATE PRIMER
P	EPOXY PRIMER

NUT MATERIAL AND FINISH DATA

CODE	MATERIAL	FINISH	LUBRICATION
CR	A-286 CRES	PASSIVATE	DRI-FILM LUBE

CLIP MATERIAL AND FINISH DATA

CODE	MATERIAL	FINISH
CR	302 CRES OR 18-2 MN CRES	PASSIVATE

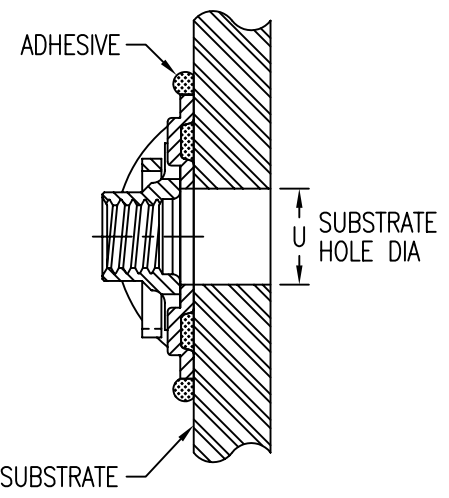

EXAMPLE PART NUMBER

CN609 CR 3 P

OPTIONAL PRIMER COATING ON BASEPLATE  
 THREAD T SIZE - .190-32 UNF-2B  
 NUT AND BASEPLATE MATERIAL - A-286 CRES  
 BASIC PART NUMBER

UNLESS OTHERWISE SPECIFIED, ALL DIMENSIONS ARE IN INCHES AND TOLERANCES ARE AS SHOWN BELOW. DIMENSIONAL TOLERANCES AND SYMBOLS PER ANSI Y14.5M-1982.

PROPRIETARY PARTS SHOWN IN THIS DRAWING ARE THE SUBJECT OF ISSUED UNITED STATES AND FOREIGN PATENTS AND PATENTS PENDING. UNAUTHORIZED REPRODUCTION AND/OR DISTRIBUTION OF THIS DRAWING IS SPECIFICALLY PROHIBITED.



CARSON CITY  
NEVADA 89706

		APPROVALS	DATE
ANGLES	±1°	DRAWN DAC	16MAY03
.XX	±.03	CHECKED DAC/MTM	16MAY03
.XXX	±.010	RELEASED DAC/MTM	16MAY03
.XXXX	±.001	REVISED DAC	16MAY03

TITLE			
NUTPLATE, TWO LUG, ADHESIVE BONDED			
SIZE	CAGE CODE	DWG. NO.	REV.
A	66530	CN609	1
SCALE	2/1 16MAY03		SHEET 1 OF 1