

BORE DIA AND THICKNESS DATA

CODE	H	A	B	T ±.005
06	.140 - .150	.62	.365 - .375	.030
08	.170 - .180	.75	.427 - .437	.030
3	.200 - .210	.87	.427 - .437	.030
4	.265 - .275	1.00	.552 - .562	.030
5	.323 - .333	1.12	.615 - .625	.040
6	.385 - .395	1.25	.677 - .687	.050

MATERIAL AND FINISH DATA

CODE	BUSHING MATERIAL	SPEC.	FINISH	SPEC.
A	2024-T3 OR -T351 ALUMINUM	QQ-A-200, QQ-A-225	NONE	
AA	2024-T3 OR -T351 ALUMINUM	QQ-A-200, QQ-A-225	ANODIZE	MIL-A-8625 TYPE I
AC	2024-T3 OR -T351 ALUMINUM	QQ-A-200, QQ-A-225	CHEMICAL CONVERSION COATING	MIL-C-5541 CLASS 3
CR	304 CRES	AMS 5639	PASSIVATE	QQ-P-35
CV	INVAR 36	UNS K93601 OR UNS K93602	NONE	
V	POLYETHERIMIDE/GLASS		POWDER BLAST	

EXAMPLE PART NUMBER

CB9029 AA 3-500

MINIMUM GRIP LENGTH L CODE - 100 (.100 INCH)

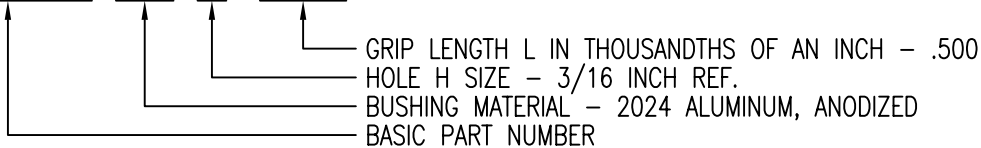

UNLESS OTHERWISE SPECIFIED, ALL DIMENSIONS ARE IN INCHES AND TOLERANCES ARE AS SHOWN BELOW. DIMENSIONAL TOLERANCES AND SYMBOLS PER ANSI Y14.5M-1982.

PROPRIETARY PARTS SHOWN IN THIS DRAWING ARE THE SUBJECT OF ISSUED UNITED STATES AND FOREIGN PATENTS AND PATENTS PENDING. UNAUTHORIZED REPRODUCTION AND/OR DISTRIBUTION OF THIS DRAWING IS SPECIFICALLY PROHIBITED.

GLICK BOND

CARSON CITY
NEVADA 89706

CAD CB9029-1		APPROVALS	DATE
ANGLES	±1°	DRAWN BPEREZ	20JUN03
.XX	±.03	CHECKED DOC/JP	20JUN03
.XXX	±.010	RELEASED CGH	20JUN03
.XXXX	±.001	REVISED BPEREZ	20JUN03

TITLE			
BUSHING, SPACER INSERT, PLAIN			
SIZE	CAGE CODE	DWG. NO.	REV.
A	66530	CB9029	12
SCALE	2/1 20JUN03		SHEET 1 OF 2

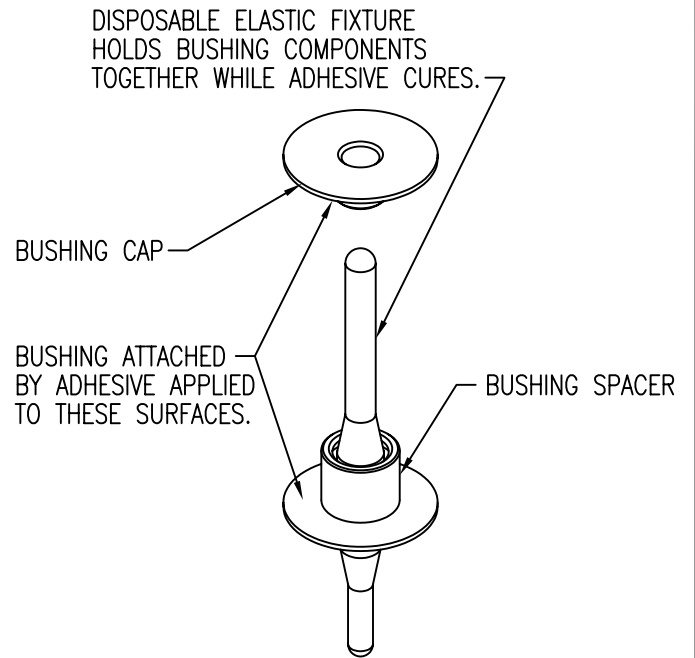
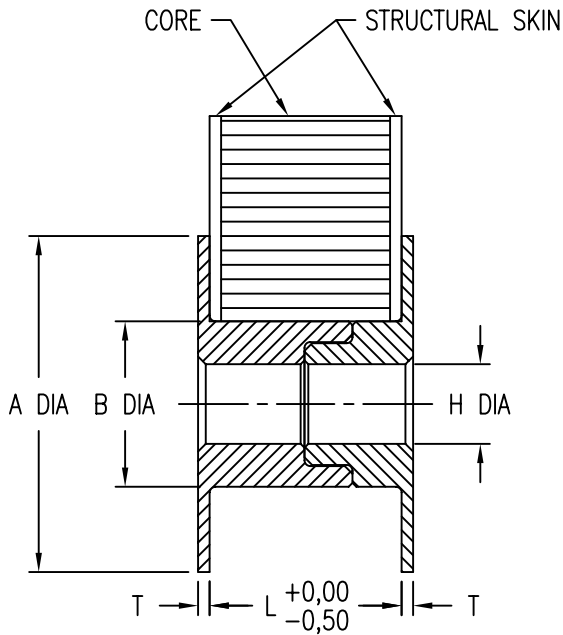

BORE DIA AND THICKNESS DATA

CODE	H	A	B	T ±0,13
3M	3,2 - 3,4	15,8	8,8 - 9,0	0,76
4M	4,2 - 4,4	19,1	9,8 - 10,0	0,76
5M	5,2 - 5,4	22,1	10,8 - 11,0	0,76
6M	6,2 - 6,4	25,4	12,8 - 13,0	0,76
8M	8,2 - 8,4	28,4	14,8 - 15,0	1,02
10M	10,2 - 10,4	31,8	16,8 - 17,0	1,27

MATERIAL AND FINISH DATA

CODE	BUSHING MATERIAL	SPEC.	FINISH	SPEC.
A	2024-T3 OR -T351 ALUMINUM	QQ-A-200, QQ-A-225	NONE	
AA	2024-T3 OR -T351 ALUMINUM	QQ-A-200, QQ-A-225	ANODIZE	MIL-A-8625 TYPE I
AC	2024-T3 OR -T351 ALUMINUM	QQ-A-200, QQ-A-225	CHEMICAL CONVERSION COATING	MIL-C-5541 CLASS 3
CR	304 CRES	AMS 5639	PASSIVATE	QQ-P-35
CV	INVAR 36	UNS K93601 OR UNS K93602	NONE	
V	POLYETHERIMIDE/GLASS		POWDER BLAST	

EXAMPLE PART NUMBER

CB9029 AA 5M 120M

MINIMUM GRIP LENGTH L CODE - 25 (2,5 MM)

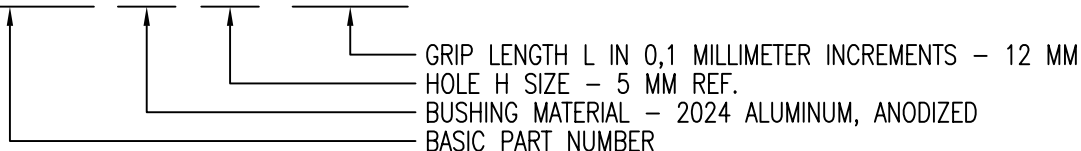

UNLESS OTHERWISE SPECIFIED, ALL DIMENSIONS ARE IN MILLIMETERS AND TOLERANCES ARE AS SHOWN BELOW. DIMENSIONAL TOLERANCES AND SYMBOLS PER ANSI Y14.5M-1982.

PROPRIETARY PARTS SHOWN IN THIS DRAWING ARE THE SUBJECT OF ISSUED UNITED STATES AND FOREIGN PATENTS AND PATENTS PENDING. UNAUTHORIZED REPRODUCTION AND/OR DISTRIBUTION OF THIS DRAWING IS SPECIFICALLY PROHIBITED.

GLICK BOND

CARSON CITY
NEVADA 89706

CAD CB9029-2
METRIC DIMENSIONS

ANGLES	±1°
.X	±0,8
.XX	±0,25

APPROVALS	DATE
DRAWN BPEREZ	20JUN03
CHECKED DOC	20JUN03
RELEASED CGH	20JUN03
REVISED BPEREZ	20JUN03

TITLE BUSHING, SPACER INSERT, PLAIN			
SIZE A	CAGE CODE 66530	DWG. NO. CB9029 (METRIC)	REV. 12
SCALE 2/1	20JUN03		SHEET 2 OF 2