

	A	B	C	D	E	F	G	SERIES 1 L DRILL	
INCH	.327	4.484	.900	.250	5.252	4.552	6.188	MAXIMUM RECOMMENDED DRILL DIAMETER	.1875 INCH
MM	8.30	113.8	22.86	6.35	133.4	115.6	157.1		4.76 mm

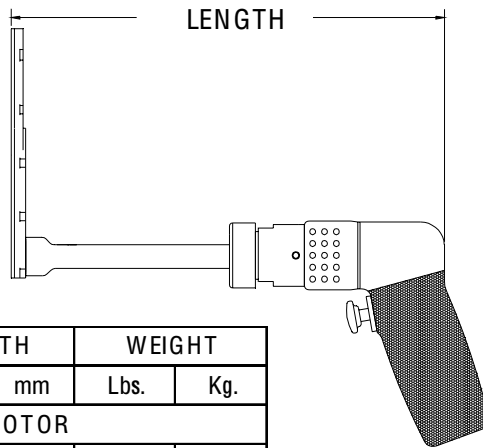

13813 ATTACHMENT ONLY EXTENDED

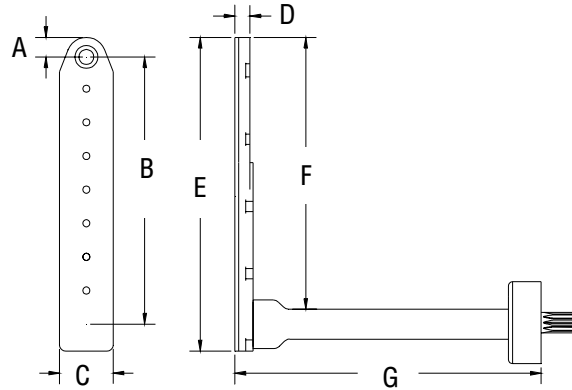

TOOL ORDER NUMBER	R.P.M.	LENGTH		WEIGHT	
		Inch	mm	Lbs.	Kg.
D SERIES .30 HP MOTOR					
16332	250	10.9	276.8	2.12	0.96
13992	500	10.9	276.8	2.12	0.96
13993	750	10.9	276.8	2.12	0.96
13994	1000	10.9	276.8	2.12	0.96
13995	1500	10.9	276.8	2.12	0.96
13996	2800	10.0	254.0	1.84	0.83
D2 SERIES .60 HP MOTOR					
16333	250	12.85	326.3	3.69	1.67
13997	450	12.25	311.1	2.99	1.35
13998	1000	12.25	311.1	2.99	1.35
13999	2000	11.00	279.4	2.74	1.24
14000	2700	11.00	279.4	2.74	1.24
14001	3500	11.00	279.4	2.74	1.24
RD2 .40 HP REVERSIBLE MOTOR					
16334	250	12.85	326.3	3.69	1.67
14003	450	12.25	311.1	3.24	1.46
14004	1000	12.25	311.1	3.24	1.46
14005	2000	11.00	279.4	2.99	1.35
14006	2700	11.00	279.4	2.99	1.35
14007	3500	11.00	279.4	2.99	1.35

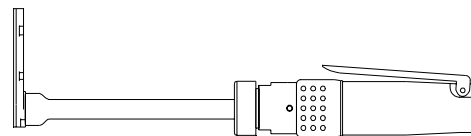

Add an S after the tool order number for the straight handle option.

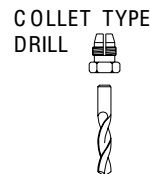

INTERNAL THREAD	
ADD TO TOOL No.	
1/4-28	A
10-32	C
9/32-40	E
5/16-24	F
COLLET	D