

	A	B	C	D	E	F	G	SERIES 1 L DRILL	
INCH	.327	1.109	.900	.250	2.250	3.106	1.858	MAXIMUM RECOMMENDED DRILL DIAMETER	.1875 INCH
MM	8.30	28.16	22.86	6.35	57.15	78.89	47.19		4.76 mm

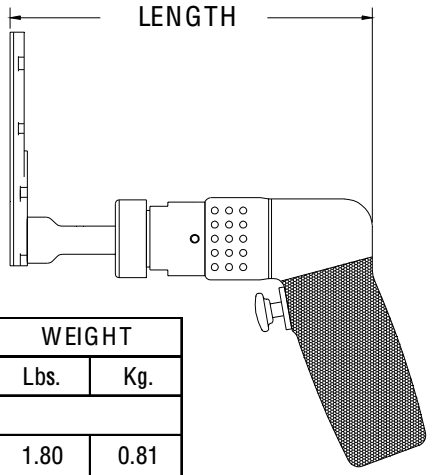

13810 ATTACHMENT ONLY SHORT

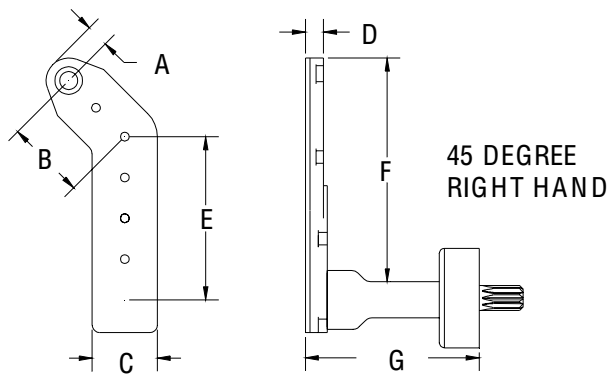

TOOL ORDER NUMBER	R.P.M.	LENGTH		WEIGHT	
		Inch	mm	Lbs.	Kg.
D SERIES .30 HP MOTOR					
16323	250	6.90	175.2	1.80	0.81
13947	500	6.90	175.2	1.80	0.81
13948	750	6.90	175.2	1.80	0.81
13949	1000	6.90	175.2	1.80	0.81
13950	1500	6.90	175.2	1.80	0.81
13951	2800	6.00	152.4	1.52	0.68
D2 SERIES .60 HP MOTOR					
16324	250	8.85	224.7	3.37	1.53
13952	450	8.25	209.5	2.67	1.21
13953	1000	8.25	209.5	2.67	1.21
13954	2000	7.00	177.8	2.42	1.09
13955	2700	7.00	177.8	2.42	1.09
13956	3500	7.00	177.8	2.42	1.09
RD2 .40 HP REVERSIBLE MOTOR					
16325	250	8.85	224.7	3.37	1.53
13957	450	8.25	209.5	2.92	1.32
13958	1000	8.25	209.5	2.92	1.32
13959	2000	7.00	177.8	2.67	1.21
13960	2700	7.00	177.8	2.67	1.21
13961	3500	7.00	177.8	2.67	1.21

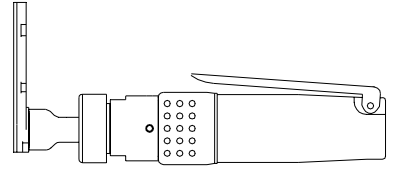

Add an S after the tool order number for the straight handle option.

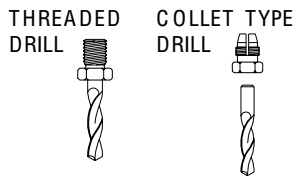

INTERNAL THREAD	
ADD TO TOOL No.	
1/4-28	A
10-32	C
9/32-40	E
5/16-24	F
COLLET	D

PHONE: 1 775 883 1072 FAX: 1 775 883 4857