

	A	B	C	D	E	F	G	SERIES 1 L DRILL	
INCH	.327	3.359	.900	.250	4.127	3.427	1.858	MAXIMUM RECOMMENDED DRILL DIAMETER	.1875 INCH
MM	8.30	85.31	22.86	6.35	104.8	87.04	47.19		4.76 mm

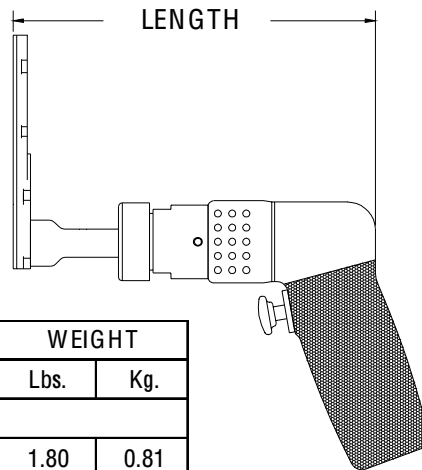

13808 ATTACHMENT ONLY SHORT

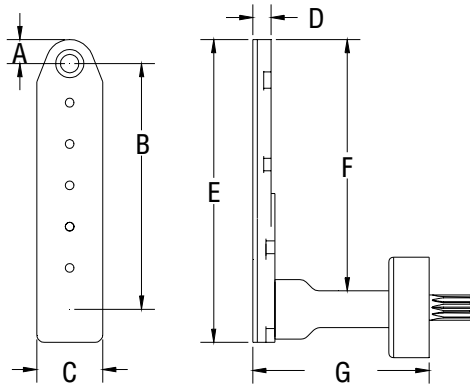

TOOL ORDER NUMBER	R.P.M.	LENGTH		WEIGHT	
		Inch	mm	Lbs.	Kg.
D SERIES .30 HP MOTOR					
16317	250	6.90	175.2	1.80	0.81
13916	500	6.90	175.2	1.80	0.81
13917	750	6.90	175.2	1.80	0.81
13918	1000	6.90	175.2	1.80	0.81
13919	1500	6.90	175.2	1.80	0.81
13920	2800	6.00	152.4	1.52	0.68
D2 SERIES .60 HP MOTOR					
16318	250	8.85	224.7	3.37	1.53
13922	450	8.25	209.5	2.67	1.21
13923	1000	8.25	209.5	2.67	1.21
13924	2000	7.00	177.8	2.42	1.09
13925	2700	7.00	177.8	2.42	1.09
13926	3500	7.00	177.8	2.42	1.09
RD2 .40 HP REVERSIBLE MOTOR					
16319	250	8.85	224.7	3.37	1.53
13927	450	8.25	209.5	2.92	1.32
13928	1000	8.25	209.5	2.92	1.32
13929	2000	7.00	177.8	2.67	1.21
13930	2700	7.00	177.8	2.67	1.21
13931	3500	7.00	177.8	2.67	1.21

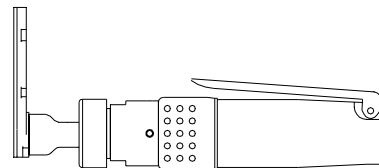

Add an S after the tool order number for the straight handle option.

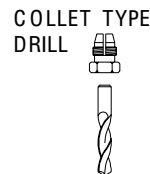

INTERNAL THREAD	
ADD TO TOOL No.	
1/4-28	A
10-32	C
9/32-40	E
5/16-24	F
COLLET	D

PHONE: 1 775 883 1072 FAX: 1 775 883 4857