

STUD STRAIGHT WITHIN .004 INCH PER INCH OF LENGTH.  
 PITCH DIAMETER CONCENTRIC WITH BASE O.D. WITHIN .020 FIM.  
 PITCH DIAMETER PERPENDICULAR TO BASE WITHIN ±1 DEG.

DISPOSABLE PRESSURE SENSITIVE ADHESIVE  
 FIXTURE HOLDS STUD WHILE ADHESIVE CURES.

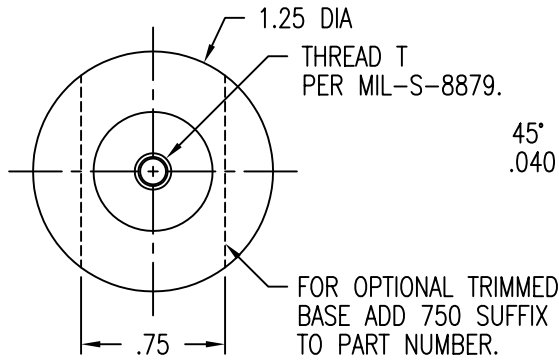

45° REF X  
 .040 MAX

1.5 INCOMPLETE  
 THDS PERMISSIBLE.

.100 MAX  
 .015 MIN

STANDARD  
 FIXTURE

OPTIONAL PRIMER  
 THIS SURFACE.

BASE SURFACE FLAT  
 WITHIN .010 FIM.

FOR OPTIONAL  
 ROUND FIXTURE  
 ADD SUFFIX R  
 TO PART NUMBER

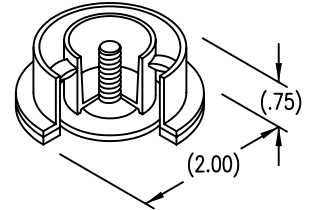
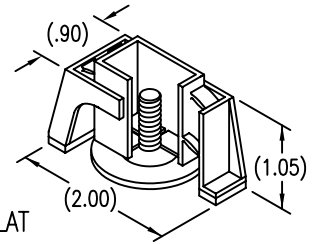

SURFACE TEXTURE: ROOT RADIUS AND THREAD FLANKS  
 32 MICROINCHES. OTHER SURFACES 125 MICROINCHES.  
 GRIT BLASTED SURFACES 125 TO 250 MICROINCHES.

LENGTH L DATA (LENGTH L IN SIXTEENTHS OF AN INCH)

CODE	4	6	8	10	12	14	16	18	20	22	24	26	28	30	32
L	.250	.375	.500	.625	.750	.875	1.000	1.125	1.250	1.375	1.500	1.625	1.750	1.875	2.000

MATERIAL AND FINISH DATA

CODE	STUD MATERIAL	SPEC.	FINISH	SPEC.
A	2024 OR 7075	QQ-A-200, QQ-A-225, OR QQ-A-250	NONE	
AA	ALUMINUM		ANODIZE	MIL-A-8625
CR	302, 303, 304 CRES OR A-286 CRES	AMS 5513, 5516, 5636, 5637, 5638, 5639, 5640, 5641, OR 5647 AMS 5525, 5726, 5731, 5732, 5734, OR 5737 (CHEMISTRY ONLY)	PASSIVATE	QQ-P-35
CRA	A-286 CRES	AMS 5525, 5726, 5731, 5732, 5734, OR 5737 (CHEMISTRY ONLY)	PASSIVATE	QQ-P-35
T	6AL-4V TITANIUM	AMS 4911, 4928, 4965, OR 4967	NONE	

THREAD T DATA

CODE	THREAD SIZE
06	.1380-32 UNJC-3A
08	.1640-32 UNJC-3A
3	.1900-32 UNJF-3A
4	.2500-28 UNJF-3A
5	.3125-24 UNJF-3A

OPTIONAL PRIMER

CODE	BASEPLATE PRIMER	SPEC.
P	EPOXY PRIMER	MIL-P-85582
W	FILM PRIMER	CBPS 211

EXAMPLE PART NUMBER

CB3000 CRA 3-12 P 750

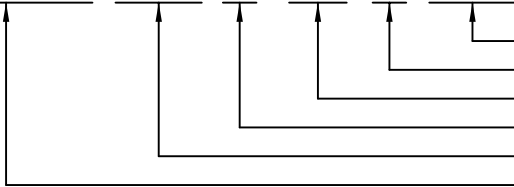

OPTIONAL TRIMMED BASE - .750  
 OPTIONAL PRIMER COATING ON BASEPLATE  
 STUD LENGTH L - .750  
 THREAD SIZE T - .1900-32 UNJF-3A  
 STUD MATERIAL - A-286 CRES  
 BASIC PART NUMBER

UNLESS OTHERWISE SPECIFIED, ALL DIMENSIONS ARE  
 IN INCHES AND TOLERANCES ARE AS SHOWN BELOW.  
 DIMENSIONAL TOLERANCES AND SYMBOLS PER ANSI  
 Y14.5M-1982.

PROPRIETARY PARTS SHOWN IN THIS DRAWING ARE THE SUBJECT  
 OF ISSUED UNITED STATES AND FOREIGN PATENTS AND PATENTS  
 PENDING.  
 UNAUTHORIZED REPRODUCTION AND/OR DISTRIBUTION OF THIS  
 DRAWING IS SPECIFICALLY PROHIBITED.

**GLICK BOND**

CARSON CITY  
 NEVADA 89706

CAD CB3000-1		APPROVALS		DATE		TITLE			
ANGLES ±1°		DRAWN	DAC	24SEP99		STUD, ADHESIVE BONDED			
.XX ±.03		CHECKED	DAC	24SEP99		SIZE	CAGE CODE	DWG. NO.	REV.
.XXX ±.010		RELEASED	CGH	30CT99		A	66530	CB3000	20
.XXXX ±.001		REVISED	DAC	24SEP99		SCALE	1/1	24SEP99	SHEET 1 OF 2

STUD STRAIGHT WITHIN .004 MM PER MM OF LENGTH.  
 PITCH DIAMETER CONCENTRIC WITH BASE O.D. WITHIN 0,5 FIM.  
 PITCH DIAMETER PERPENDICULAR TO BASE WITHIN ±1 DEG.

DISPOSABLE PRESSURE SENSITIVE ADHESIVE  
 FIXTURE HOLDS STUD WHILE ADHESIVE CURES.

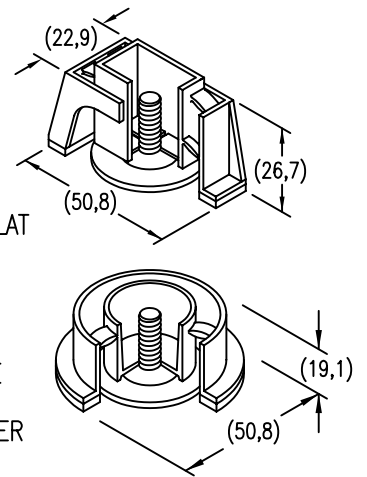
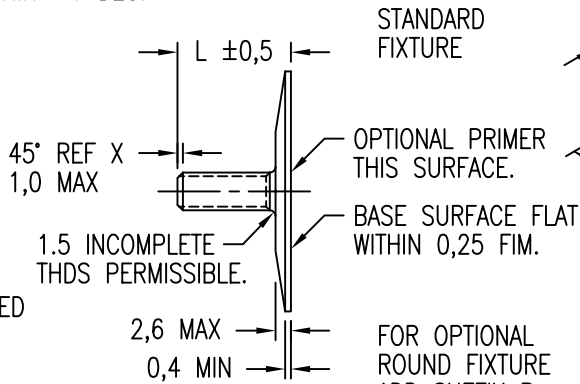
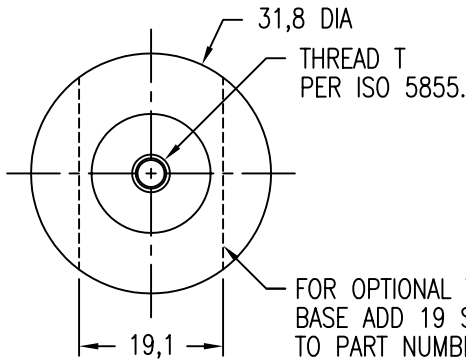

SURFACE TEXTURE: ROOT RADIUS AND THREAD FLANKS  
 0,8 MICROMETERS. OTHER SURFACES 3,2 MICROMETERS.  
 GRIT BLASTED SURFACES 3,2 TO 6,3 MICROMETERS.

FOR OPTIONAL  
 ROUND FIXTURE  
 ADD SUFFIX R  
 TO PART NUMBER

LENGTH L DATA (LENGTH L IN MILLIMETERS)

CODE	6M	8M	10M	12M	15M	20M	25M	30M	35M
L	6	8	10	12	15	20	25	30	35

MATERIAL AND FINISH DATA

CODE	STUD MATERIAL	SPEC.	FINISH	SPEC.
A	2024 OR 7075	QQ-A-200, QQ-A-225, OR QQ-A-250	NONE	
AA	ALUMINUM		ANODIZE	MIL-A-8625
CR	302, 303, 304 CRES OR A-286 CRES	AMS 5513, 5516, 5636, 5637, 5638, 5639, 5640, 5641, OR 5647 AMS 5525, 5726, 5731, 5732, 5734, OR 5737 (CHEMISTRY ONLY)	PASSIVATE	QQ-P-35
CRA	A-286 CRES	AMS 5525, 5726, 5731, 5732, 5734, OR 5737 (CHEMISTRY ONLY)	PASSIVATE	QQ-P-35
T	6AL-4V TITANIUM	AMS 4911, 4928, 4965, OR 4967	NONE	

THREAD T DATA

CODE	THREAD SIZE
3M	MJ3 X 0,5 4h6h
4M	MJ4 X 0,7 4h6h
5M	MJ5 X 0,8 4h6h
6M	MJ6 X 1,0 4h6h
8M	MJ8 X 1,0 4h6h

OPTIONAL PRIMER

CODE	BASEPLATE PRIMER	SPEC.
P	EPOXY PRIMER	MIL-P-85582
W	FILM PRIMER	CBPS 211

EXAMPLE PART NUMBER

CB3000 CRA 5M 15M P 19

OPTIONAL TRIMMED BASE - 19,1 MM  
 OPTIONAL PRIMER COATING ON BASEPLATE  
 STUD LENGTH L - 15 MM  
 THREAD SIZE T - MJ5 X 0,8 4h6h  
 STUD MATERIAL - A-286 CRES  
 BASIC PART NUMBER

UNLESS OTHERWISE SPECIFIED, ALL DIMENSIONS ARE  
 IN MILLIMETERS AND TOLERANCES ARE AS SHOWN  
 BELOW. DIMENSIONAL TOLERANCES AND SYMBOLS  
 PER ANSI Y14.5M-1982.

PROPRIETARY PARTS SHOWN IN THIS DRAWING ARE THE SUBJECT  
 OF ISSUED UNITED STATES AND FOREIGN PATENTS AND PATENTS  
 PENDING. UNAUTHORIZED REPRODUCTION AND/OR DISTRIBUTION OF THIS  
 DRAWING IS SPECIFICALLY PROHIBITED.

**GLICK BOND**

CARSON CITY  
 NEVADA 89706

CAD CB3000-2 METRIC DIMENSIONS	
ANGLES	±1°
.X	±0,8
.XX	±0,25

APPROVALS	DATE
DRAWN DAC	24SEP99
CHECKED DAC	24SEP99
RELEASED CGH	30OCT99
REVISED DAC	24SEP99

TITLE STUD, ADHESIVE BONDED			
SIZE A	CAGE CODE 66530	DWG. NO. CB3000 (METRIC)	REV. 20
SCALE 1/1	24SEP99	SHEET 2 OF 2	